

# emDrive H10

HIGH VOLTAGE MOTOR CONTROLER

TRACTION, PROPULSION & WORK FUNCTION ELECTRIFICATION



PRODUCT DATASHEET

## PRODUCT OVERVIEW

**emDrive electric Motor Controllers** are designed for traction, propulsion, work functions, and electro-hydraulic systems.

Suitable for heavy duty off-highway machinery for construction, agriculture, mining, material handling, airport ground support as for electric boats and power-sports vehicles, it ensures reliable and efficient performance across various mobile applications.



emDrive shares common unique value propositions

- **Compactness** Unmatched continuous power density
- **Efficiency** Smart motor control unlocking full system performance and energy savings
- **Safety** Compliance with the latest electrical safety, environmental, EMC and functional safety
- **Modularity** One platform, multiple voltage options – Switch without system redesign

## EMDRIVE MAIN FEATURES

emDrive are rugged motor controllers for mobile applications. Main features are:

- Advanced motor control algorithm for precise control of **AC, PM, and SyRM motors**
  - Torque and Velocity control for precise, smooth and responsive regulation
  - Generator mode to supply stable DC voltage - with PMSM motors
  - Overmodulation for full battery voltage utilization, enabling higher motor performances
  - Dynamic calculation of power stage and motor temperature for maximum performance
  - Dynamic switching frequency for optimal efficiency
  - Reliable system operation with linear derating and protection functions
  - Sensor or sensorless operation for reduced hardware
- Universal motor position sensor interface - supports digital and analogue sensors
- Configurable safe state behavior: Active Short Circuit (ASC) or open terminals
- Supports CAN communication protocols, including J1939 and UDS
- Advanced diagnostics and fast data acquisition
- Active discharge and pre-charge functionality
- HV voltage safety
  - Active and passive discharge
  - Isolated HVIL input (High voltage interlock loop)

Motor controllers can be supplied with emDrive Configurator PC software allowing real-time data acquisition, parameterization, diagnostics, firmware upgrading and application programming.

## TABLE OF CONTENTS

Product overview .....	2
emDrive main features .....	2
Table of contents .....	2
Specifications .....	3
Safety and compliance .....	4
Mechanics .....	5
Wiring .....	6
Model code .....	7

## SPECIFICATIONS

### Key performances

emDrive	H10B-400-SD	H10B-800-SD	unit
Continuos current S1			
Liquid cooled (power loss)	100 (600)	50 (600)	A <sub>RMS</sub> (W)
Air cooled	85	50	A <sub>RMS</sub>
Chassis mount	28	17	A <sub>RMS</sub>
Peak current S2 -60sec			
Liquid cooled (power loss)	150 (950)	75 (1000)	A <sub>RMS</sub> (W)
Air cooled	140	70	A <sub>RMS</sub>
Chassis mount	140	70	A <sub>RMS</sub>

**Operating conditions:** Space vector modulation (SVM) at 80%, Load cos phi >0.98, Switching frequency 8 kHz

- **Liquid cooled:** Coolant temperature 60 °C, Ambient temperature 60 °C, Coolant flow 5 l/min, 50:50 water/glycol
- **Air cooled:** Ambient temperature 30 °C, reference fined heatsink LA 35 300 12 FISCHER ELEKTRONIK
- **Chassis mount:** Ambient temperature 30 °C, Free hanging Steel plate 800 x 800 x 6 mm, Air flow 3 m/s

### Electrical characteristics

emDrive	H10B-400-SD	H10B-800-SD	unit
DC link operating voltage	12* to 420	12* to 800**	V
DC link capacitance	650 ±10%	200 ±10%	µF
Insulation to heatsink (basic)	1100	2000	V
Supply voltage (KL15/KL30 voltage)	9 to 36	9 to 36	V
Supply current (max. Ignition current)	1,0	1,0	A
Switching frequency (adjustable)	4-16	4-16	kHz

\* In case of ASC functionality minimum voltage is 200V.

\*\* on request up to 870 V. For further information see ordering chapter.

### Environmental characteristics

emDrive	H10B-400-SD	H10B-800-SD	unit
Operating ambient temperature	-40 to 85		°C
Max. ambient temperature (no derating)	60		°C
Operating coolant temperature *	-40 to 85		°C
Max coolant temperature (no derating) *	60		°C
Nominal coolant flow *	5		l/min
Max. operating pressure *	2		bar
Pressure drop @ 5 l/min & 25 °C *	0,03		bar

\* LC variant. Note: 50/50 mixture of distilled water and glycol with glycol-tolerant hoses.

### Mechanical characteristics

emDrive	H10B-400-SD		H10B-800-SD		unit
Cooling	LC	AC	LC	AC	/
Mass	4500	5000	4500	5000	g
Dimensions (Height x Width x Length)	96 x 271 x 183	94 x 271 x 183*	96 x 271 x 183	94 x 271 x 183*	mm
Material (housing)	Aluminum				/

\* Dimensions without reference heatsink

## Communication and sensor connections

Communication	Motor feedback
<ul style="list-style-type: none"> <li>• J1939, UDS, CANopen (DSP402 compatible)</li> <li>• Proprietary CAN messaging based on DBC</li> <li>• Optional                             <ul style="list-style-type: none"> <li>○ XCP</li> <li>○ Secondary CAN interface</li> <li>○ CAN FD</li> </ul> </li> <li>• Cybersecurity related features                             <ul style="list-style-type: none"> <li>○ Secure FW upgrade</li> <li>○ Authorization algorithms for secure access to parameters and features</li> <li>○ Use of CPU security features to prevent reading memory and changing content</li> </ul> </li> </ul>	<ul style="list-style-type: none"> <li>• Supports multiple position sensor types:                             <ul style="list-style-type: none"> <li>○ Sin/Cos differential &amp; single-ended</li> <li>○ Resolver</li> <li>○ SSI (Synchronous Serial Interface)</li> <li>○ Hall sensors</li> <li>○ AB encoders</li> </ul> </li> <li>• One or two connections for temperature sensing                             <ul style="list-style-type: none"> <li>○ Supported sensors PT100, PT1000, NTC and KTY</li> </ul> </li> </ul>

## SAFETY AND COMPLIANCE

### Functional safety

Development and design according to ISO25119, considered ISO19014 on system level and safety function aligned with EN1175 & IEC 61800. SAE J1939-76 Functional safety communication protocol. PL levels of machinery under ISO 13849 can be met following equivalence with ISO25119. Three core CPU compliant with ISO 26262 ASIL D.

Supported safety functions – AgPL-C performance level		
Stopping	Monitoring	Output
Safe Torque Off (STO)	Safe Operating Stop (SOS)	Safe Brake Control (SBC)
Safe Stop 1 (SS1)	Safely Limited Speed (SLS)	Main contactor control
Safe Stop 2 (SS2)	Safely Limited Acceleration (SLA)	Safe outputs reserved for specific apps
	Safe Speed Range (SSR)	
	Safe Limited Torque (SLT)	
	Safe Torque Range (STR)	
	Safe Direction (SDI)	
	Driver presence detection - CAN or general input	
	Emergency stop detection - CAN or general input	
	Safe inputs reserved for specific apps	

### Compliance

Compliance	Standard
<b>Electrical safety</b>	EN 61800-5-1
<b>Functional safety</b>	ISO 25119 EN ISO 13849 EN ISO 19014 (considered for system level HARA) EN 61800-5-2 (safety functions) EN 1175 (safety functions)
<b>Environment</b>	IP rating IP66 & IP69K (with mated connectors) Random vibration ISO 16750-3:2023, Test XVI, 10 Hz – 2000 Hz, 31.9 m/s <sup>2</sup> Shock ISO 16750-3:2023, Shock II, 500 m/s <sup>2</sup> , 6 ms, half-sine Free fall ISO 16750-3:2023, 0.25 m
<b>EMC</b>	UN ECE R10 Rev.6 EN ISO 13766-1 EN ISO 13766-2 EN ISO 14982 EN 12895
<b>Compliance</b>	CE

# MECHANICS

## H10 Liquid Cooled – Slim system connector (EMDI-2-H10B-xxx-xx-L0-x-x-S2-1)

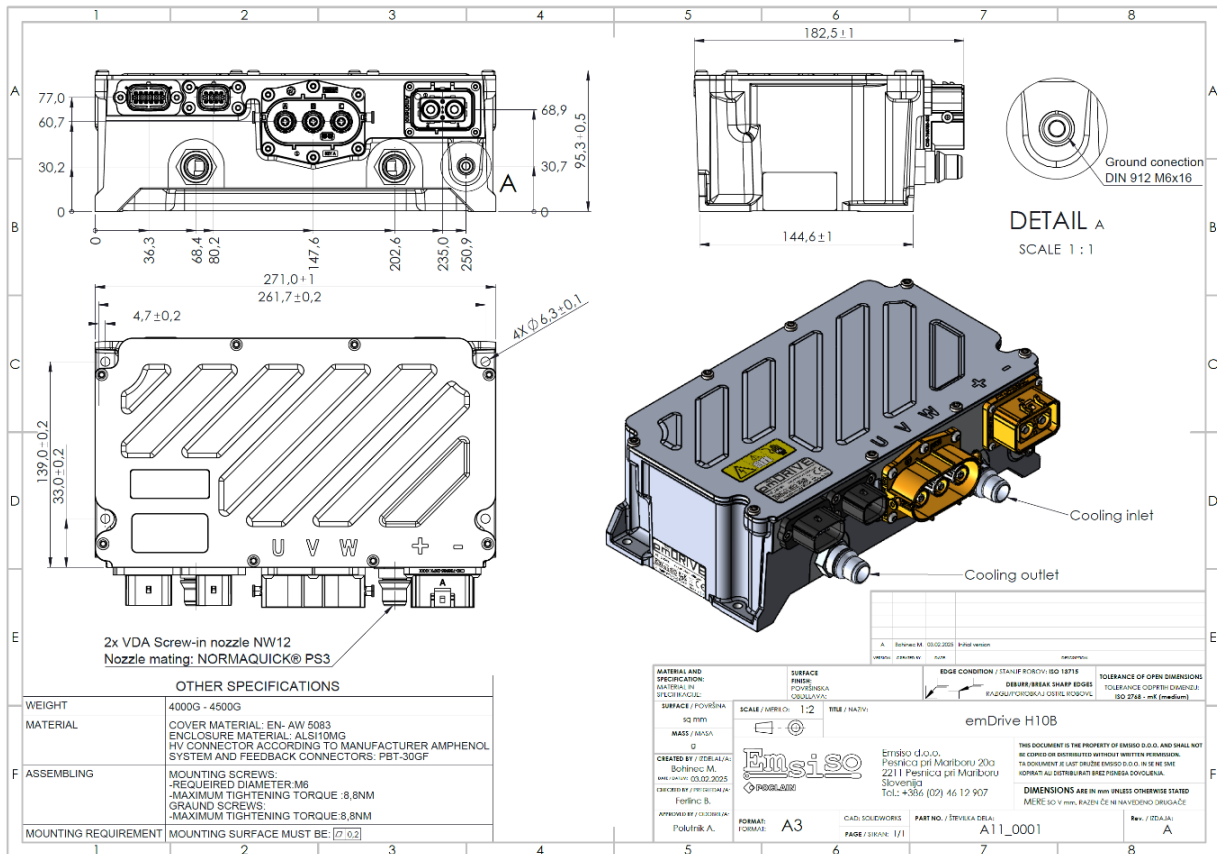

## H10 Air cooled – Slim system connector (EMDI-2-H10B-xxx-xx-A0-x-x-S2-1)

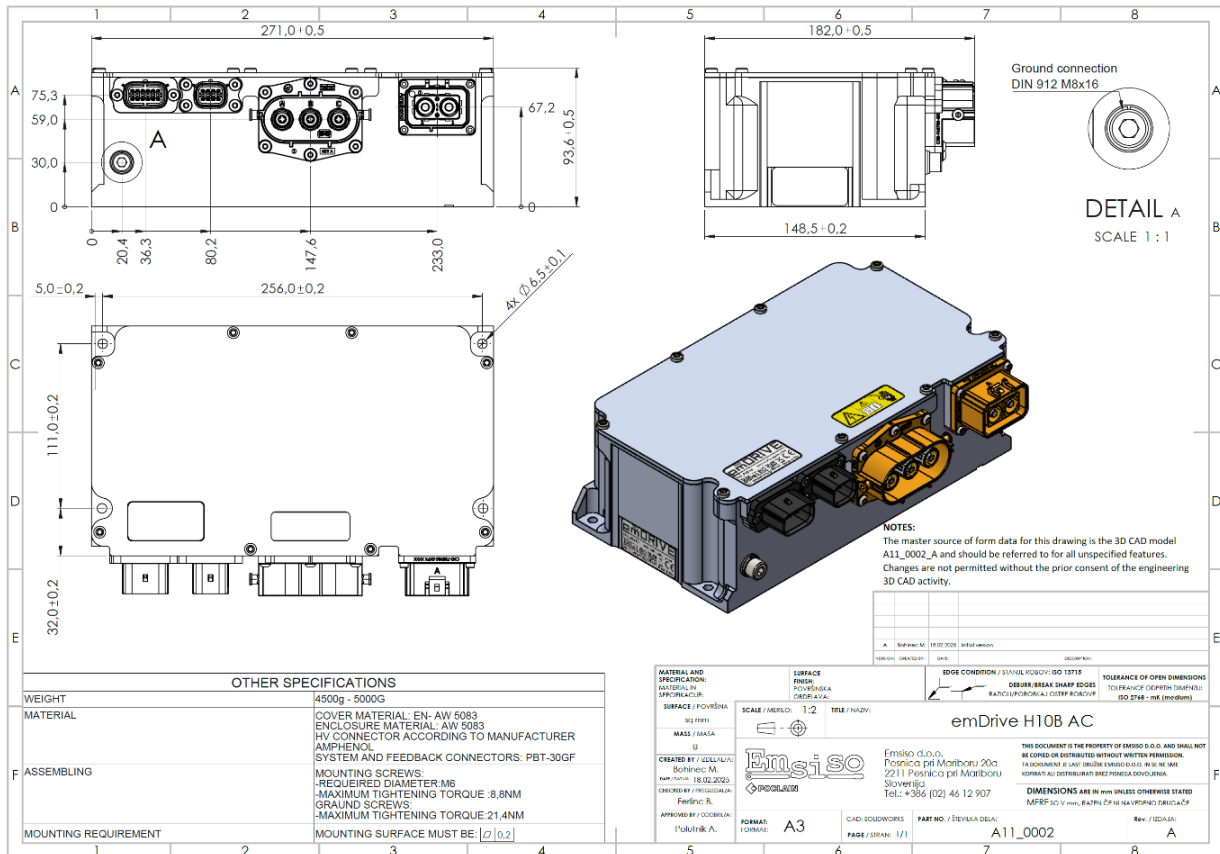

## WIRING

### Feedback connector details

Molex MX 150, Keying option A, 12 pin (Mating part<sup>1</sup>: 12 pin Molex PN 334721206)

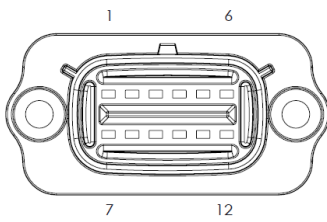

	1	2	3	4	5	6
Resolver	EXC +	EXC -	SIN +	SIN -	COS +	COS -
SIN/COS	5V supply	GND	SIN +	SIN -	COS +	COS -
SIN/COS single	5V supply	GND	SIN +	/	COS +	/
SSI	5V supply	GND	Data + (Rx)	Data - (Rx)	Clock + (Tx)	Clock - (Tx)
Hall	5V supply	GND	Hall U	Hall V	Hall W	Index
AB encoder	5V supply	GND	Enc A	Enc B	/	Enc Z
	TEMP 1 GND	TEMP 1	TEMP 2 GND (CAN2 L)*	TEMP 2 (CAN2 H)*	SHIELD (CAN2 GND)*	SHIELD
	7	8	9	10	11	12

\* CAN 2 is optional HW configuration (see ordering information).

### System connector details

Molex MX 150, Keying option A, 8 pin (Mating part<sup>1</sup>: 8 pin Molex PN 334724806)

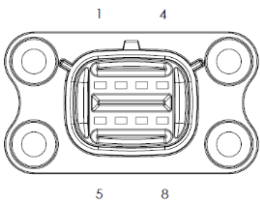

1	2	3	4
GND (KL31)	CAN1 L	CAN1 GND	HVIL -
KL30	CAN1 H	KL15	HVIL +
5	6	7	8

KL30=Logic supply, KL15= Logic supply - Ignition, HVIL= High Voltage interlock

### Power connection description

Connector	Description	Mating connector
Connector DC	ELRA2A03 - ePower lite from Amphenol 5.7 mm 2-pole contact	ELPA2A25
Connector AC	ELRA3A03 - ePower lite from Amphenol 5.7 mm 3-pole contact	ELPA3A25

<sup>1</sup> For reliable vibration and galvanic corrosion protection recommended mating contacts shall be gold plated.

## MODEL CODE

Product code = Product base code + options/variants code

Example of product code: EMDI-2-H10B-400-SD-L0-0-0-S2-1 -> **EMDI2H10B400SDL000S21**

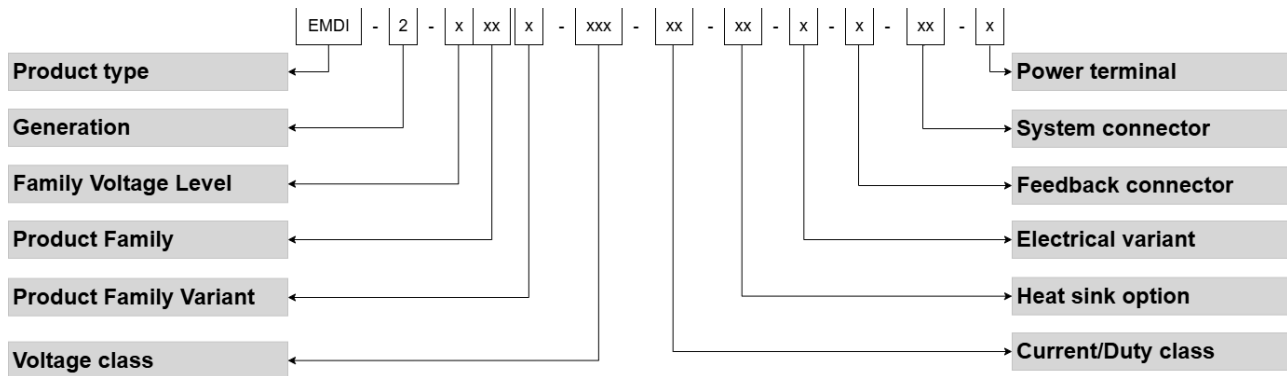

### Product base code

Type	Gen	Level	Product Family	Family Variant	Voltage class	Current class	Heat sink
EMDI	2	H	10	B	400	SD	L0=liquid A0=Air
EMDI	2	H	10	B	800	SD	L0=liquid A0=Air

### Options/variants codes for voltage class 400

Electrical variant	Feedback connector	System connector	Power terminal/connector
0=default (SW conf. ASC) 1*=nonASC	0=2x Motor temp. 1*=1x Motor temp., 1x CAN2	S2=CAN1 + HVIL	1=Plug-in

### Options/variants codes for voltage class 800

Electrical variant	Feedback connector	System connector	Power terminal/connector
0=default (SW conf. ASC) 1*=nonASC 2*=870V, ASC 3*=870V, nonASC	0=2x Motor temp. 1*=1x Motor temp., 1x CAN2	S2=CAN1 + HVIL	1=Plug-in

\* For further information please contact <https://poclain.com/contact-us>



[www.poclain.com](http://www.poclain.com)