

MI250

HYDRAULIC MOTORS

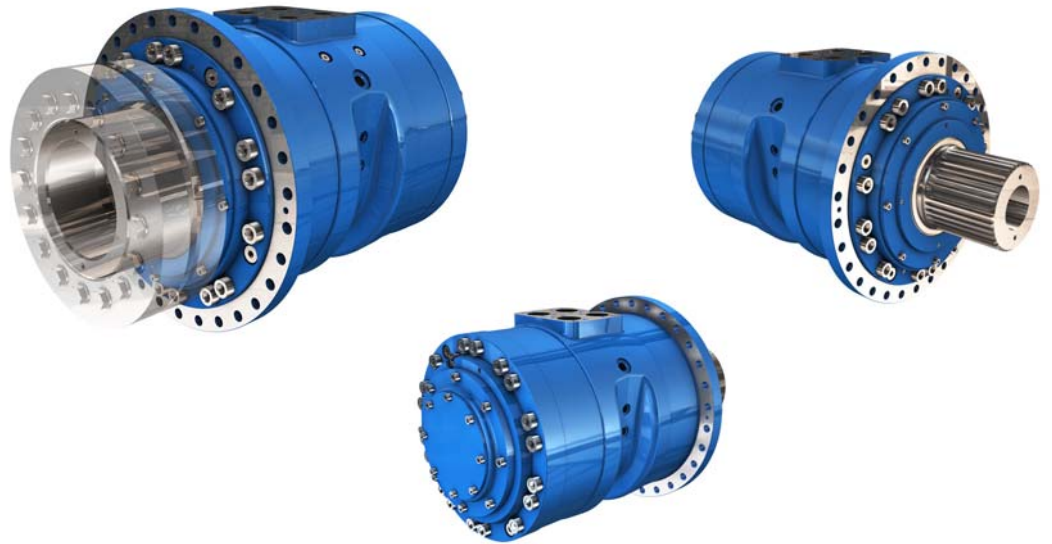

T E C H N I C A L C A T A L O G



CHARACTERISTICS

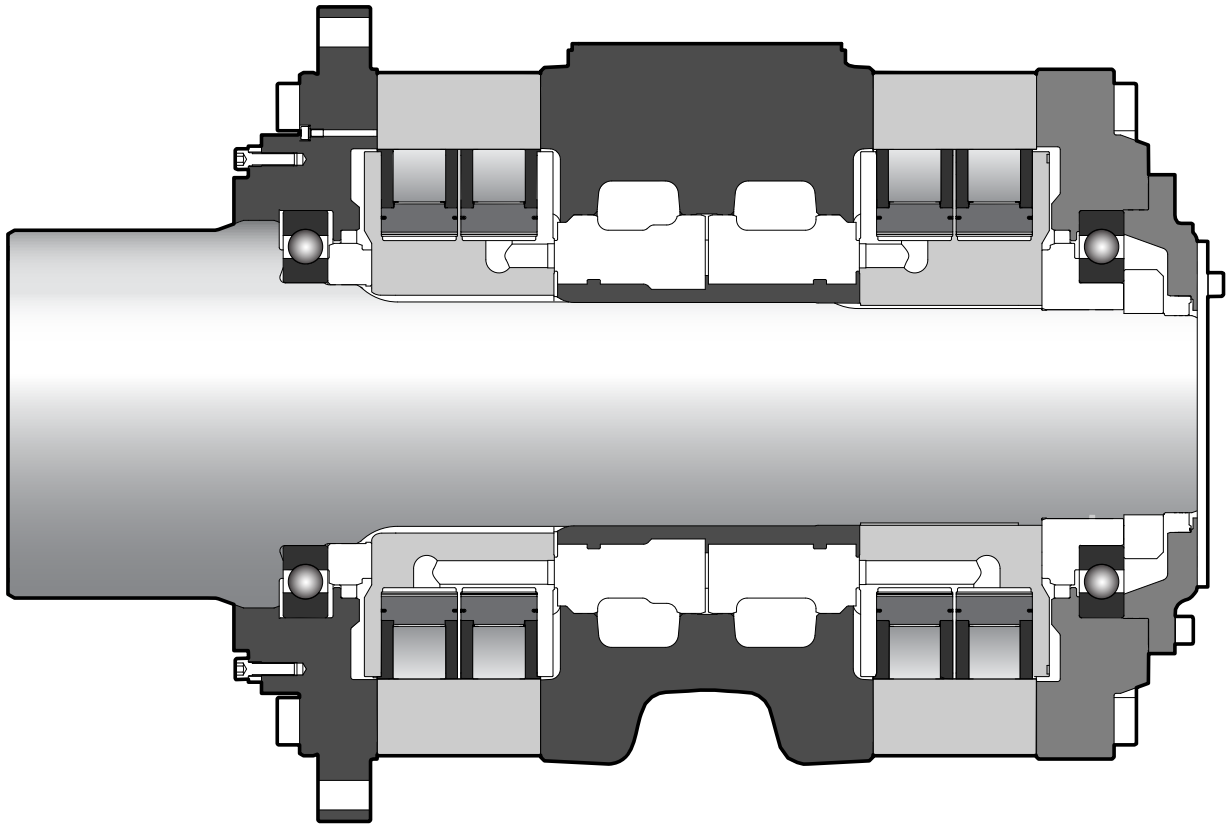

C	Displacemen cm ³ /tr [cu.in/rev.]		Theoretical torque		Max.power kW [HP]	Max.speed [RPM]	Max. pressure bar [PSI]	
			at ΔP 100 bar Nm	at ΔP 1000 PSI [lb.ft]				
7	17 500	[1 067]	27 582	[14 150]	500 [671]	100	450	[6 527]
8	20 000	[1 220]	31 800	[16 171]		90		
9	22 500	[1 372]	35 775	[18 193]		80	415	[6 019]
0	25 000	[1 525]	39 750	[20 214]		72		
1	27 500	[1 677]	43 725	[22 235]		65	380	[5 511]
2	30 000	[1 830]	47 700	[24 257]		60	350	[5 076]



CONTENT



MODEL CODE

4

Model code

MOTORS

7

Motors

- Motor with splined shaft 7
- Motor with shrink disc 8
- Motor with female splines 9
- Coupling for female splines 10

VALVING SYSTEM

11

Valving systems

- Hydraulic connections 11
- Efficiency curves 12
- Pressure drop and charge pressure 13

INSTALLATION

15

Installation

- Torque arms mounting 15
- Recommended torque arm design for MI250 15
- Chassis mountings 16

OPTIONS

17

Options

ACCESSORIES

21

Accessories

- Shrink disc 21
- Anticavitation valve (VAC) 22



MODEL

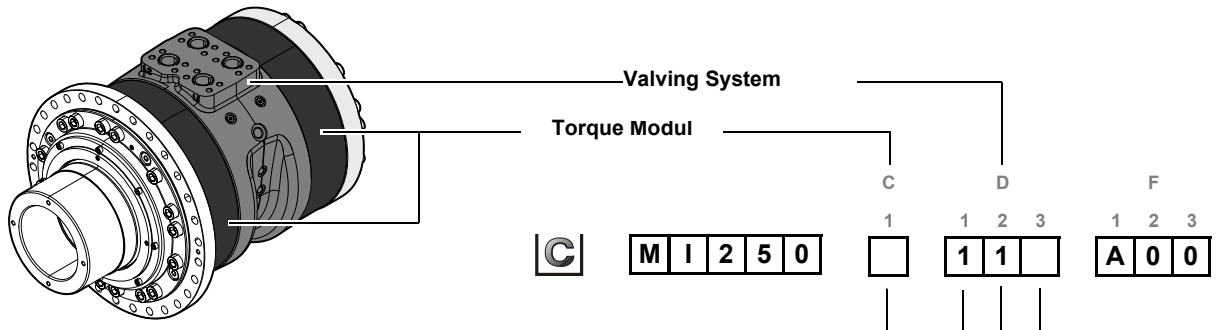

C1

Cam ring type

1 displacement

cm³/tr [cu.in./rev.]

17 500 [1 067]

20 000 [1 219]

22 500 [1 372]

25 000 [1 524]

27 500 [1 677]

30 000 [1 829]

7

8

9

0

1

2

D1

Valving type

1-displacement valving

1

D2

Valving cove

Without mounting

1

D3

Connection type

HP: ISO 6162-2 (SAE flanges) DN38

BP: ISO 1179-1 (GAZ) Connections

HP: ISO 6162 (SAE flanges) DN38

BP: ISO 11926-1 (SAE J514) Connection

2

A



CODE

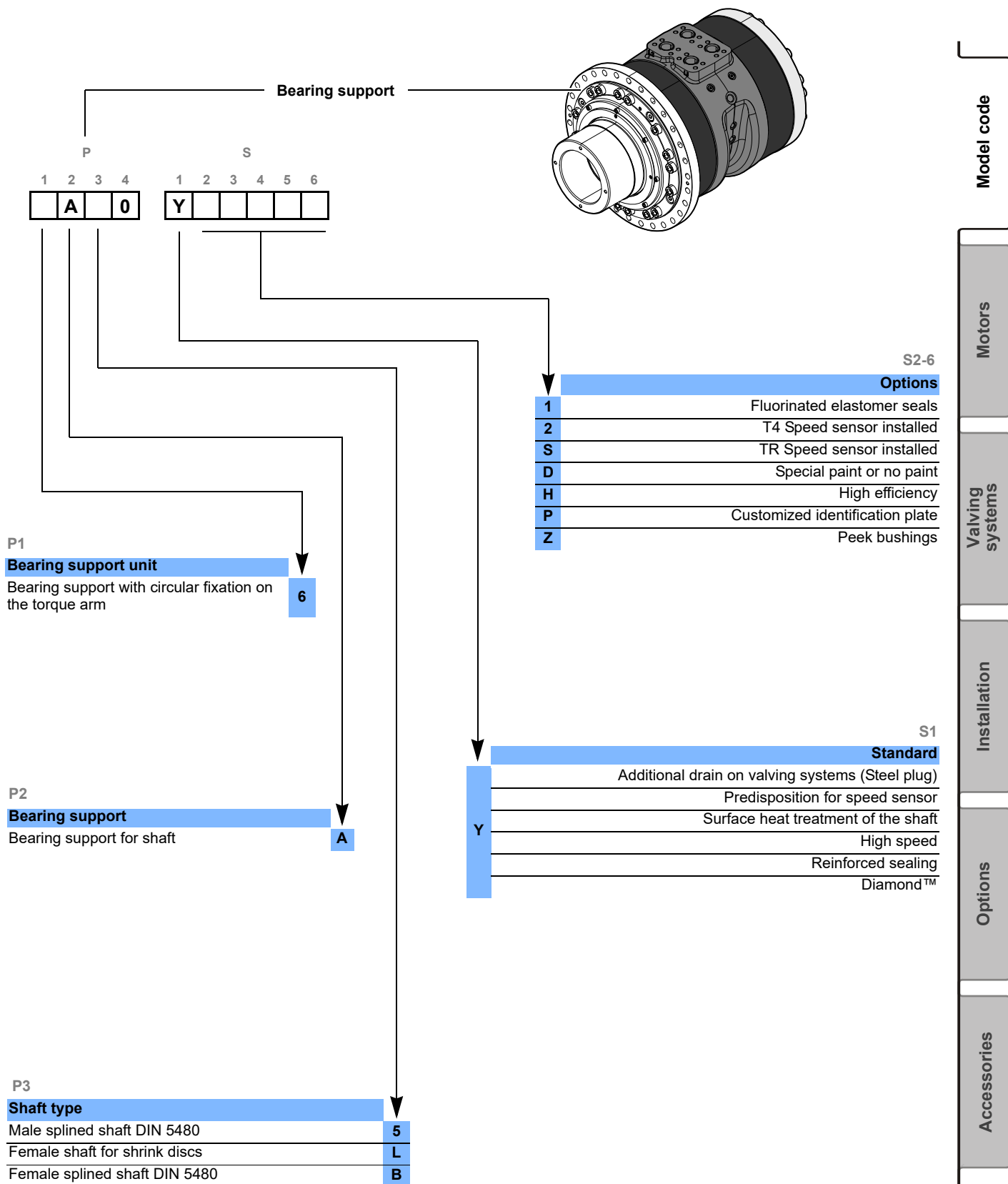



Methodology :

This document is intended for manufacturers of machines that incorporate Poclain Hydraulics products. It describes the technical characteristics of Poclain Hydraulics products and specifies installation conditions that will ensure optimum operation. This document includes important comments concerning safety. They are indicated in the following way:



Safety comment.

This document also includes essential operating instructions for the product and general information. These are indicated in the following way:



Essential instructions.



General information.



Information on the model number.



Weight of component without oil.



Volume of oil.



Units.



Tightening torque.



Screws.



Information intended for Poclain-Hydraulics personnel.

The views in this document are created using metric standards.
The dimensional data is given in mm and in inches (inches are given in brackets in italics).





MOTORS

Motor with splined shaft

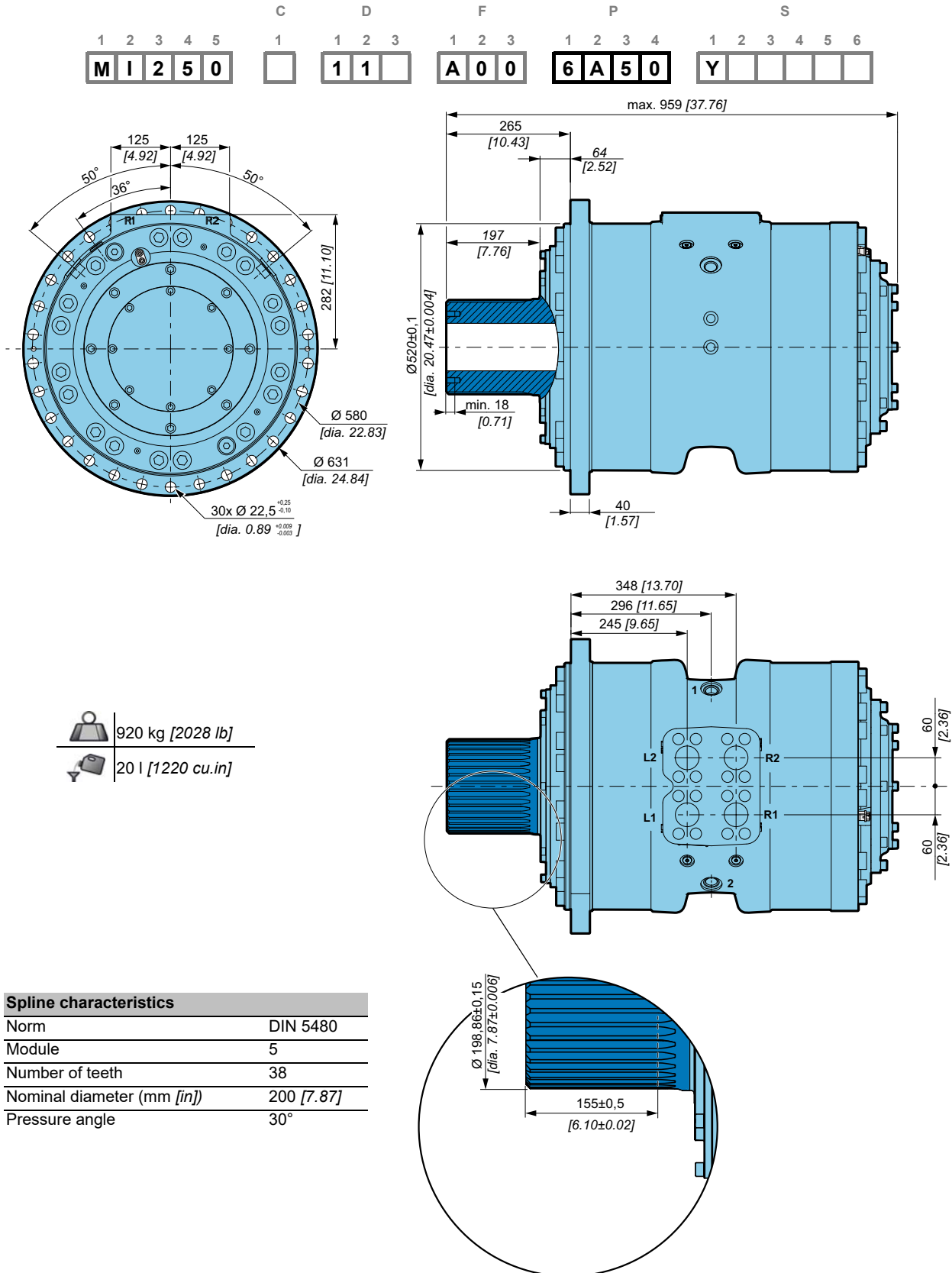

Model code

Motors

Valving systems

Installation

Options

Accessories



Motor with shrink disc

					C	D			F			P				S					
1	2	3	4	5	1	1	2	3	1	2	3	1	2	3	4	1	2	3	4	5	6
M	I	2	5	0		1	1		A	0	0	6	A	L	0	Y					

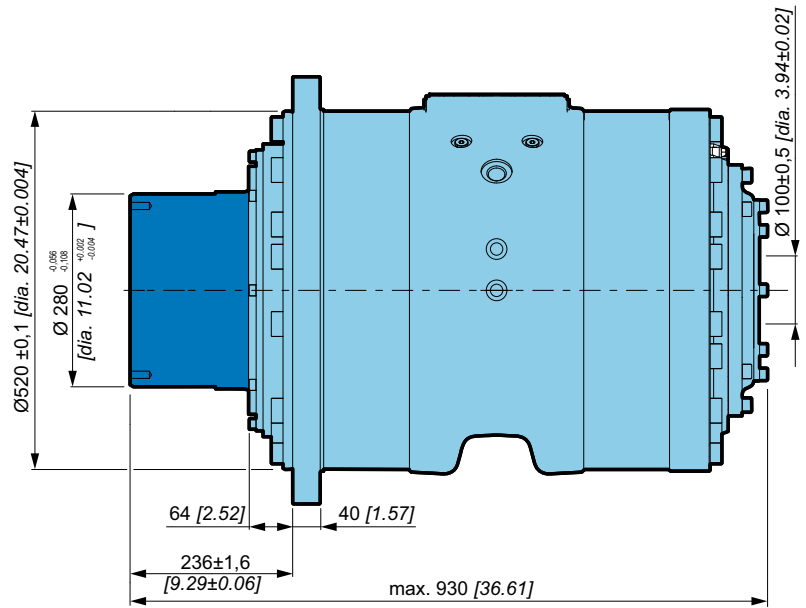
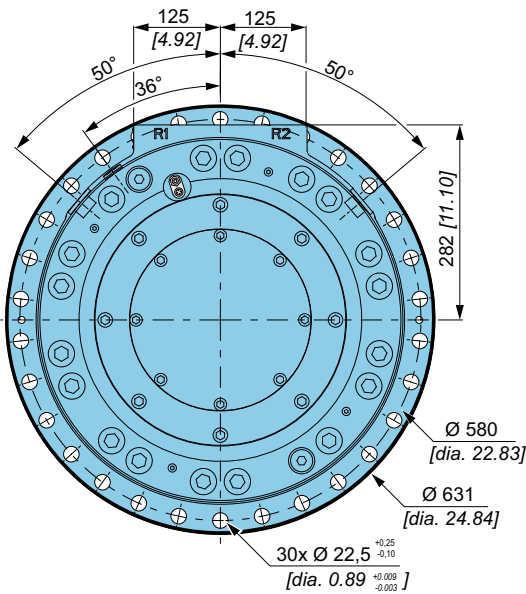

	940 kg [2070 lb]
	20 l [1220 cu.in]

Coupling for shrink discs

C	A (1) mm [in]	B mm [in]
6 A L 0	Ø 200 [7,87 dia.]	127 [5,00]
1 2 3 4 P		

(1) - 0,015 [- 0.0006]
- 0,061 [- 0.0024]

R min. : 640 N/mm² [132 800 PSI]

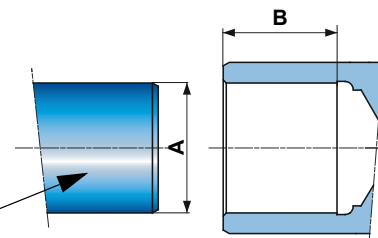



Motor with female splines

					C	D			F			P				S					
1	2	3	4	5	1	1	2	3	1	2	3	1	2	3	4	1	2	3	4	5	6
M	I	2	5	0		1	1		A	0	0	6	A	B	0	Y					

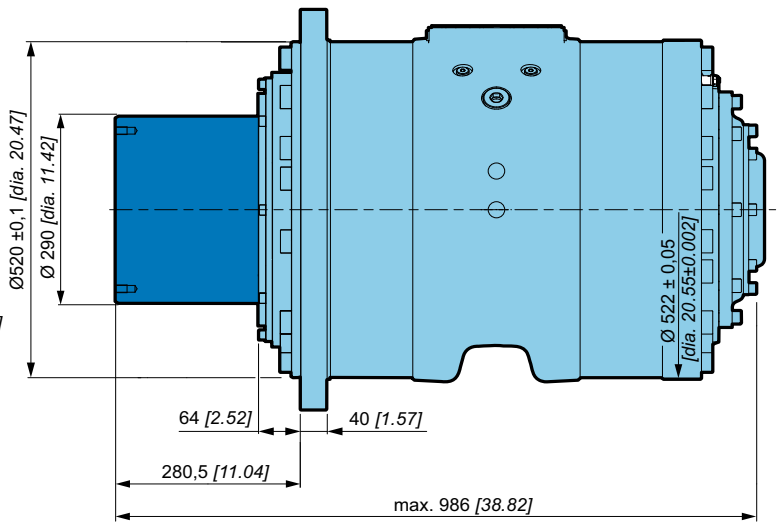
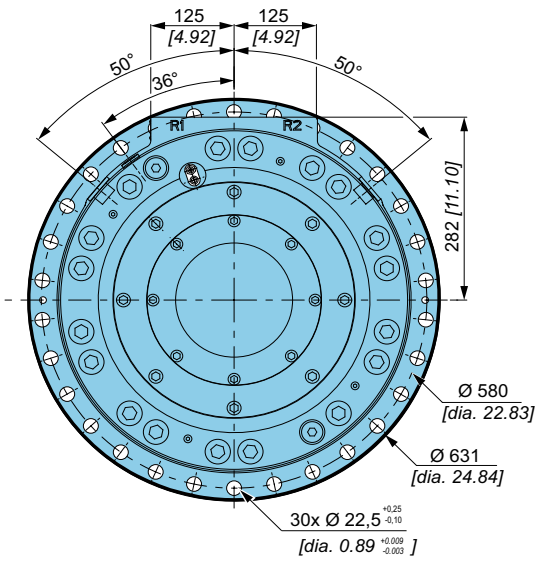

	975 kg [2149 lb]
	21 l [1281 cu.in]

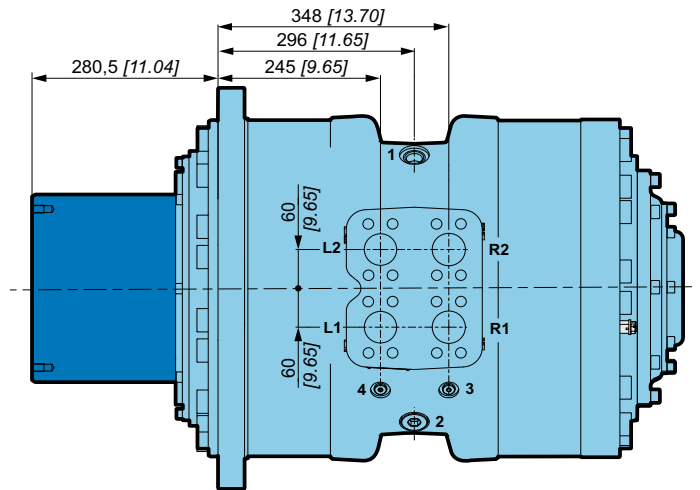

Model code

Motors

Valving systems

Installation

Options

Accessories



Coupling for female splines

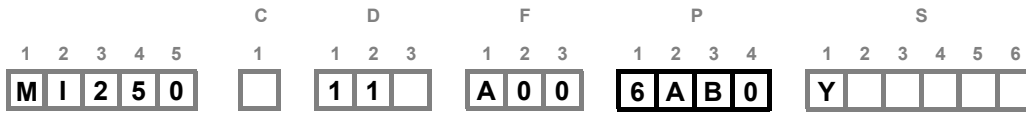

Spline characteristics

Norm	DIN 5480
Module	5
Number of teeth	38
Nominal diameter (mm [in])	200 [7.87]
Pressure angle	30°
Tolerance class	9H

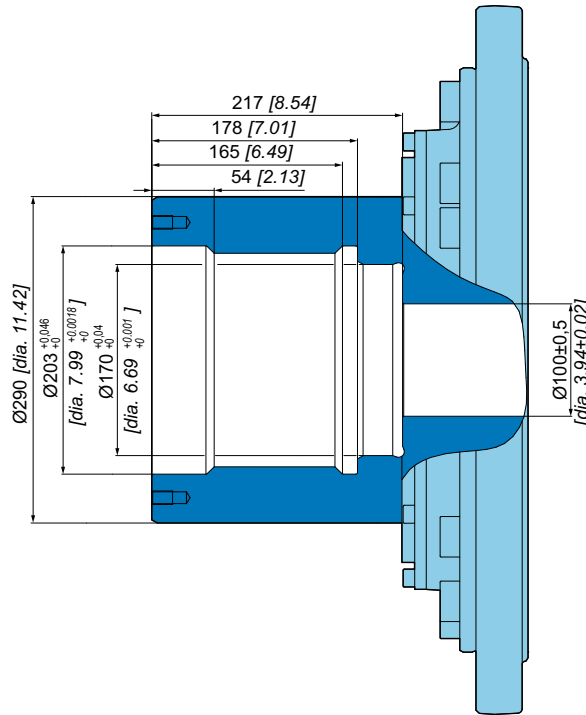

Recommended customer shaft design for bearing support 6AB0

	Torque arm motor	Flange mounted moto
A ⁽¹⁾	Ø170 [6,69 dia.]	Ø170 [6,69 dia.]
B ⁽²⁾	Ø203 [7,99 dia.]	Ø203 [7,99 dia.]
E	10,0 [0,39]	5,0 [0,20]
F	130,0 [5,12]	130,0 [5,12]
G	44,0 [1,73]	36,0 [1,42]
LU	131,0 [5,16]	131,0 [5,16]
	(1) - 0,014 [-0.0005] - 0,039 [- 0.001]	(2) -0,115 [-0.004] - 0,144 [- 0.005]

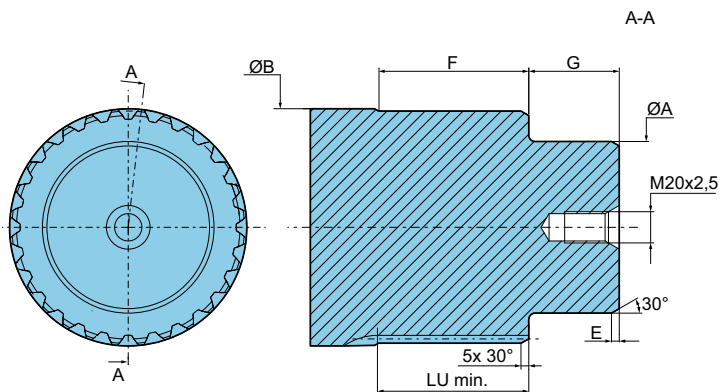

For torque arm mounting, both motor and customer shaft must be in axial contact (no axial play) and must have sealing between motor and customer shaft.



For chassis mounting, an axial play must be ensured between motor and customer shaft.



Consult your Poclair Hydraulics application engineer.



VALVING SYSTEM

Hydraulic connections

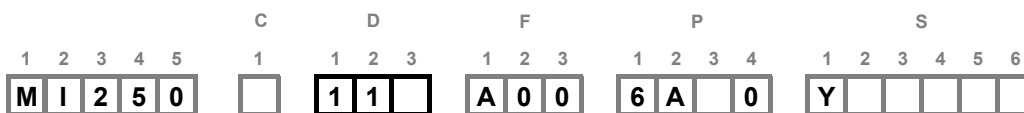
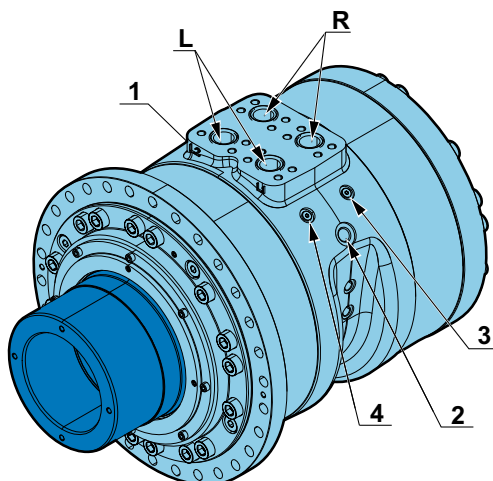

		Power supply	Case drain	Pressure gauge
		R-L	1 - 2	3 - 4
			GAZ (BSPP)	GAZ (BSPP)
		ISO 6162-2	ISO 1179-1	ISO 1179-1
	2	DN 38	G1	G1/4
		ISO 6162-2	ISO 11926-1	ISO 11926-1
	A	DN 38	1" 1/16-12 UNF	9/16"-18 UNF
Max. pressure	bar [PSI]	450 [6 527]	2,5 [36]	450 [6 527]
Peak pressure	bar [PSI]	-	15 [218]	-



You are strongly advised to use the fluids specified in brochure "Installation guide" N° B59689D.



To find the connections' tightening torques, see the brochure "Installation guide" N° B59689D.

Model code

Motors

Valving systems

Installation

Options

Accessories



Efficiency curves

Overall efficiency

Average values given for guidance for code 0 displacement after 100 hours of operation with HV46 hydraulic fluid at 50°C [122°F].

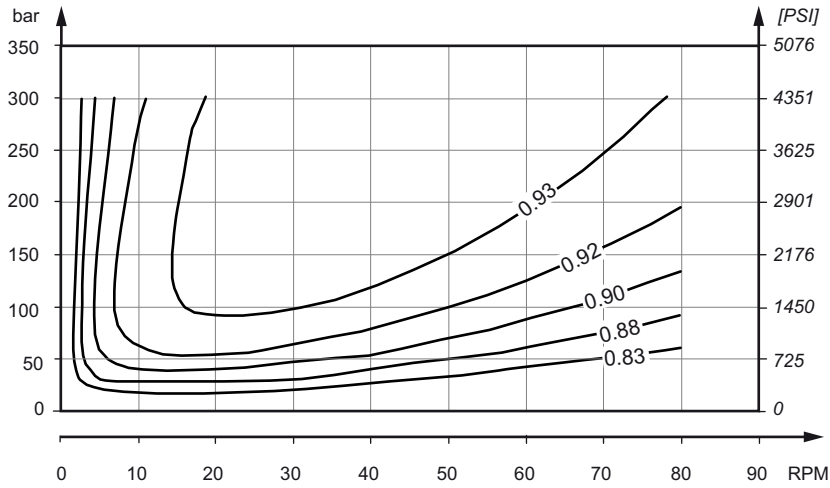

For a precise calculation, consult your Poclain Hydraulics application engineer.



Pressure drop and charge pressure

Pressure drop (With Hv46 hydraulic fluid at 50 °C [122 °F],oil viscosity 30 Cst)

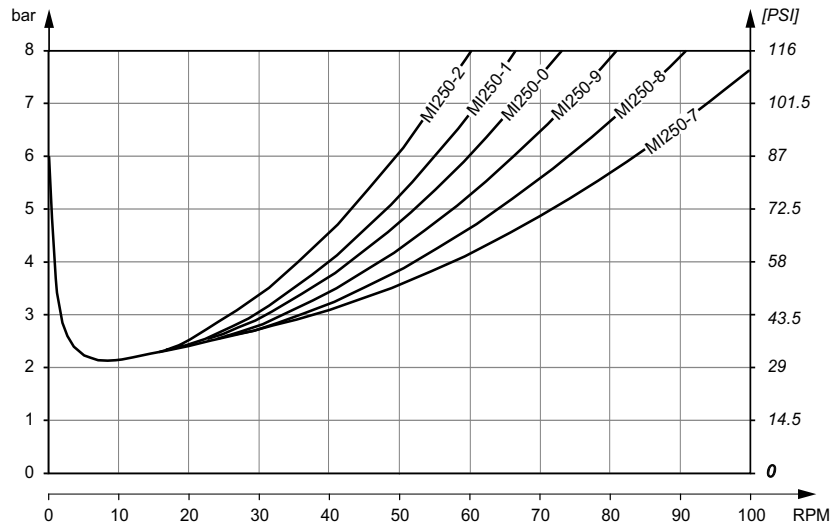

Charge pressure (With HV46 hydraulic fluid at 50 °C [122 °F],oil viscosity 30 cSt)

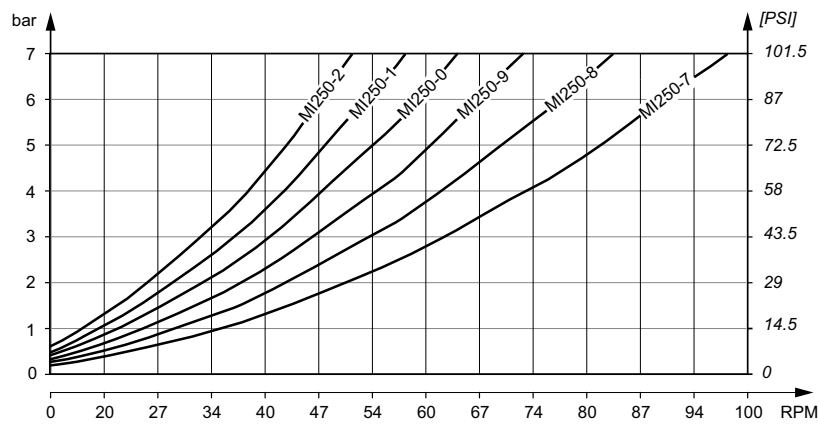

For a precise calculation, consult your Poclain Hydraulics application engineer.

Model code

Motors

Valving systems

Installation

Options

Accessories





INSTALLATION

Torque arms mounting

We recommend a length of the torque arm of 1250 mm [49.21 in].

In order to avoid residual forces due to misalignment and twisting, the end of the arms must retain freedom of movement in 2 axis.

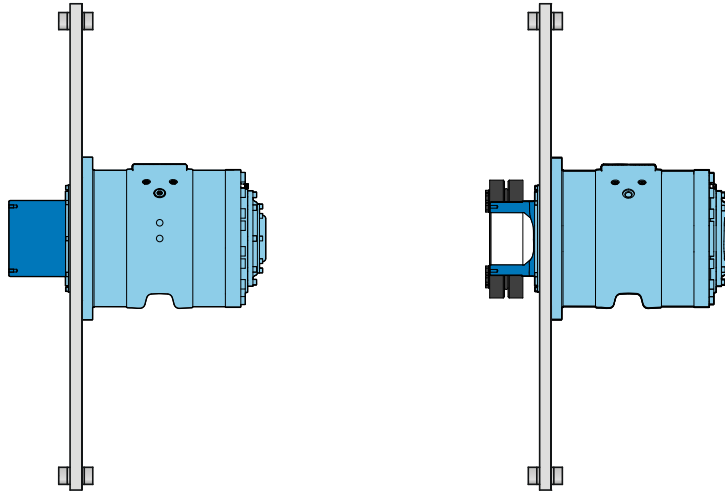

Recommended torque arm design for MI250

Torque arm can be supplied by Poclair Hydraulics. It must be ordered separately.

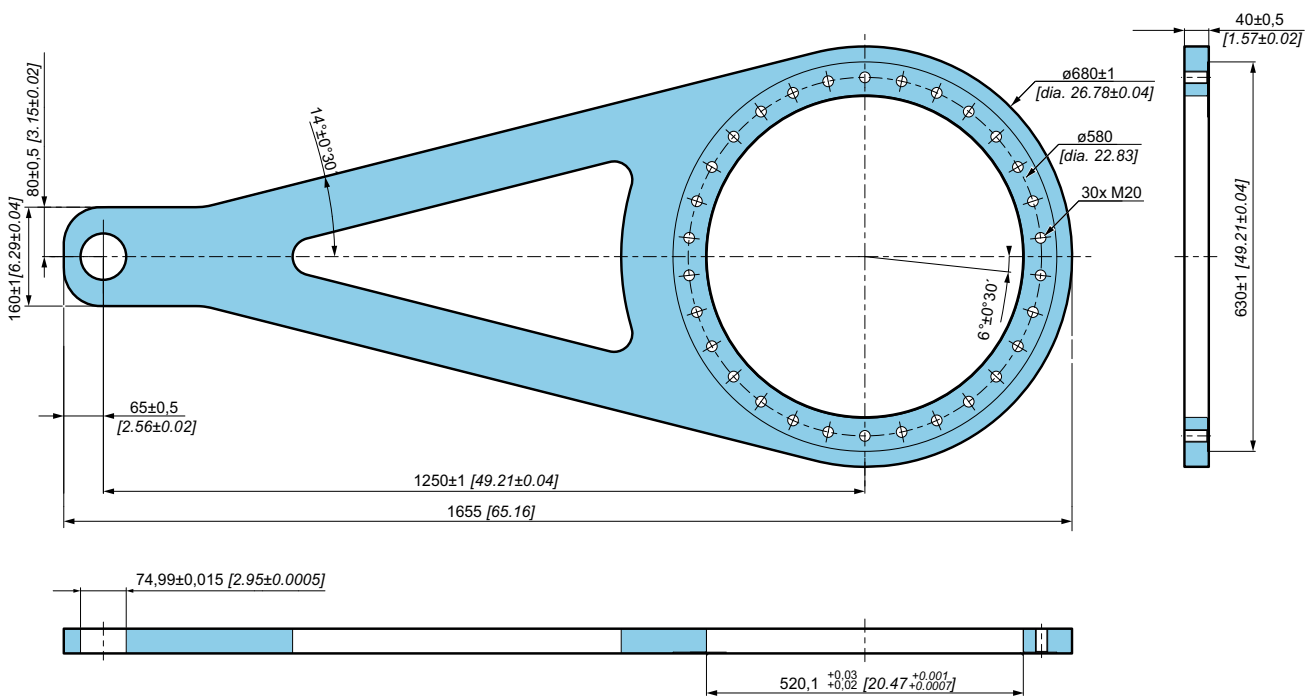

For a precise calculation, consult your Poclair Hydraulics application engineer.



Chassis mountings

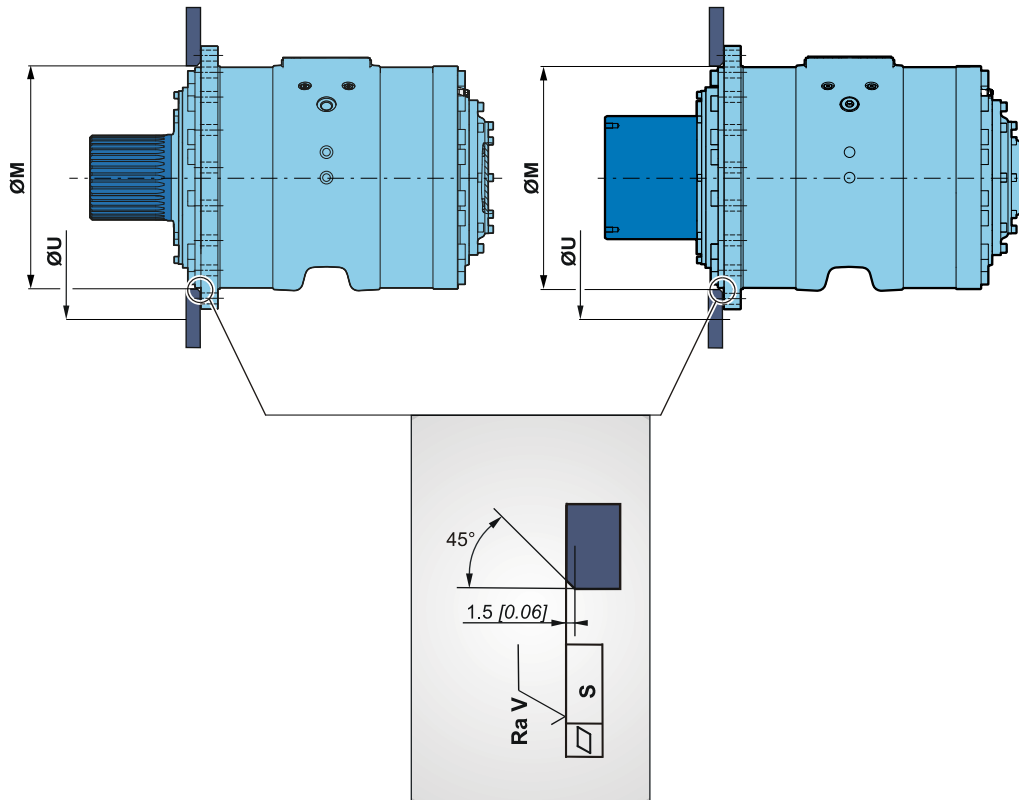

Take care over the immediate environment of the connections.

$\varnothing M$ ⁽¹⁾ mm [in]	$\varnothing U$ mm [in]	S mm [in]	Ra V $\mu\text{m} [\mu\text{in}]$	Class
520,1 [20,48]	640 [22,24]	0,2 [0,008]	12,5 [0,49]	12.9

(1) +0,3 [+0,012]
+0,2 [+0,008]



OPTIONS

					C	D			F			P				S					
1	2	3	4	5	1	1	2	3	1	2	3	1	2	3	4	1	2	3	4	5	6
M	I	2	5	0		1	1		A	0	0	6	A		0	Y					



You can accumulate more than one optional part. Consult your Poclain Hydraulics sales engineer.

Y Standard option

- Additional drain on valving system (steel plug)
- Predisposition for speed sensor
- Surface heat treatment on the shaft
- High speed
- Reinforced sealing
- Diamond™

Drain on the valving system

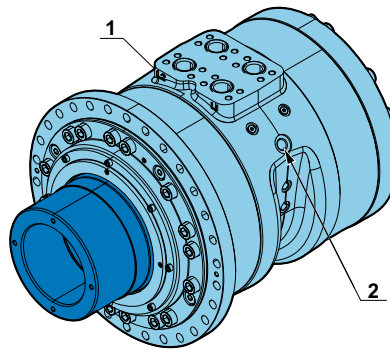

Surface heat treatment on the shaft

Heat treatment on the indicated bearing radius and splines.

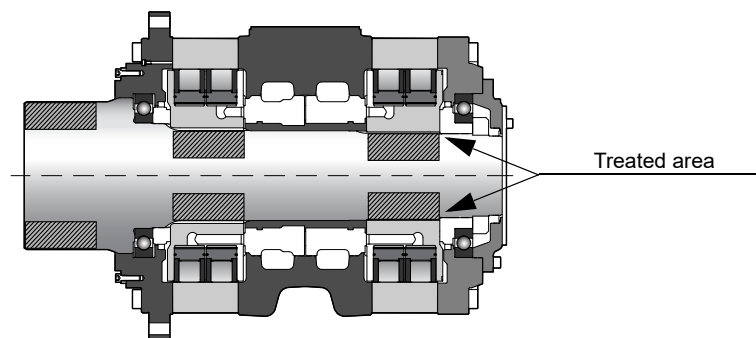

Diamond™

Special treatment of the motor core which considerably increases its strength, making the motor much more tolerant to temporary instances of the operating conditions being exceeded.

- Model code
- Motors
- Valving systems
- Installation
- Options
- Accessories



2 S Installed speed sensor or predisposition

Designation

T4 Speed sensor installed	2
TR Speed sensor installed (direction of rotation)	S

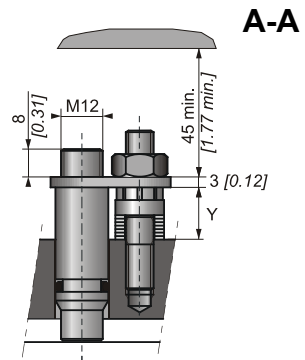

Max. length Y= 18,65 [0.73]

Standard number of pulses per revolution= 120



Look at the "Mobile Electronic" N° A01889D technical catalogue for the sensor specifications and its connection.



To install the sensor, see the "Installation guide" brochure No. B61352L.

1 Fluorinated elastomer seals

Nitrile seals marked in the figure below replaced by fluorinated elastomer seals.

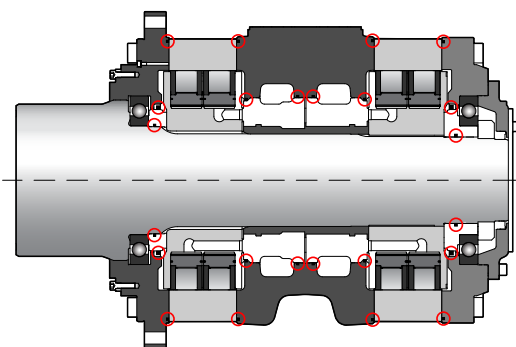

Consult your Poclain Hydraulics sales engineer.

D Special paint or no paint

The motors are delivered with Poclain Hydraulics yellow ochre primer as standard.



Consult your Poclain Hydraulics application engineer for other colors of primer or topcoat



H High efficiency

Reinforced piston sealing to improve volumetric efficiency.



For a precise calculation, consult your Poclain Hydraulics application engineer.

P Customized identification plate

Your part number can be engraved on the plate.



Consult your Poclain Hydraulics application engineer for other possibilities.

Z PEEK bushings

Mechanical, chemical and thermal resistance.

- Model code
- Motors
- Valving systems
- Installation
- Options
- Accessories





ACCESSORIES

Shrink disc

Shrink disc can be supplied for motor MI250 using bearing support 6AL0.

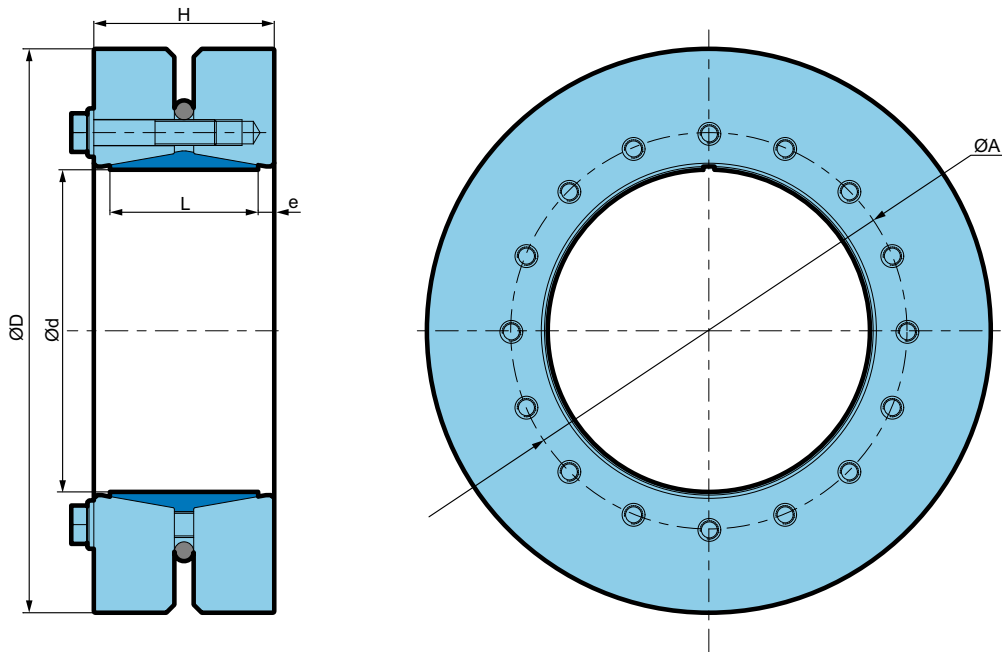

d	D	H	L	e	A	Screws	Mt-max	Mass
mm [in]	mm [in]	mm [in]	mm [in]	mm [in]	mm [in]		Nm [lbf]	kg [lbs]
280 [11.02]	460 [18.11]	134 [5.28]	114 [4.49]	10 [0.39]	346 [13.62]	16x M20x100	179 000 [132 020]	99 [218]

Model code

Motors

Valving systems

Installation

Options

Accessories

**Anticavitation valve (VAC)**

- Flanged on MI250 flat ports
- Protect motor against cavitation risk
- Available with two positions of accumulator

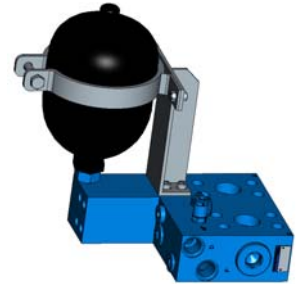
**Description**

This valve, which is directly flanged on the MI250, will offer enhanced protection of the motor against possible cavitation during operation, by ensuring sufficient back pressure on the motor (additional flow provided by the accumulator).

This valve is available with 2 positions for the accumulator (0° or 90°).

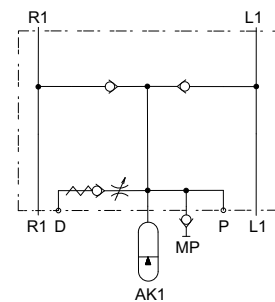
Hydraulic symbol**Features****Valve**

Max. pressure	bar [PSI]	450 [6 526]
Fluid viscosity	mm ² /s [ssu]	15 to 380 [69.5 to 1 760]
Required fluid filtration	ISO 4406	18/16/13
Surface protection	DIN 50979	Fe/ZN8/Cn/T2

Accumulator

Precharge pressure	bar [PSI]	12 [174]
Volume	l [GPM]	2 [0.53]

Hydraulic connections

Port	Function	Connections		Max. pressure bar [PSI]
		GAZ ISO 1179-1	ISO 6162-2	
P	Pressure line	G3/4	-	30 [435]
D	Drain			
L1	Motor line - L1	-	PN400 DN32	450 [6 526]
R1	Motor line - R1			



Pressure drop

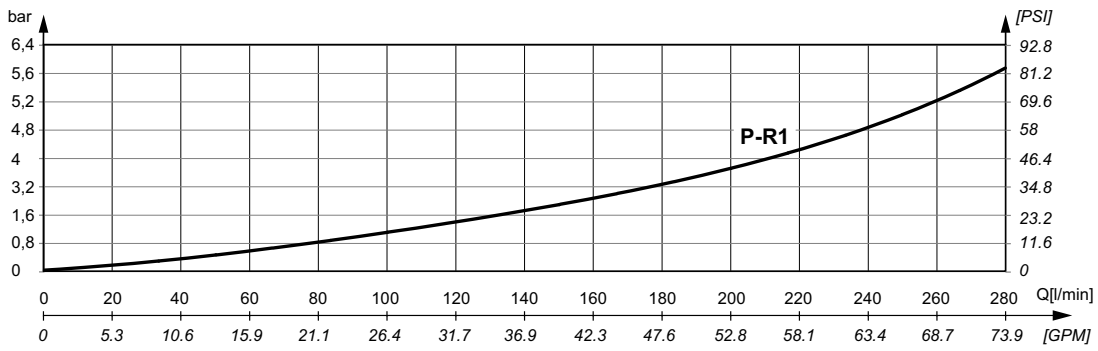
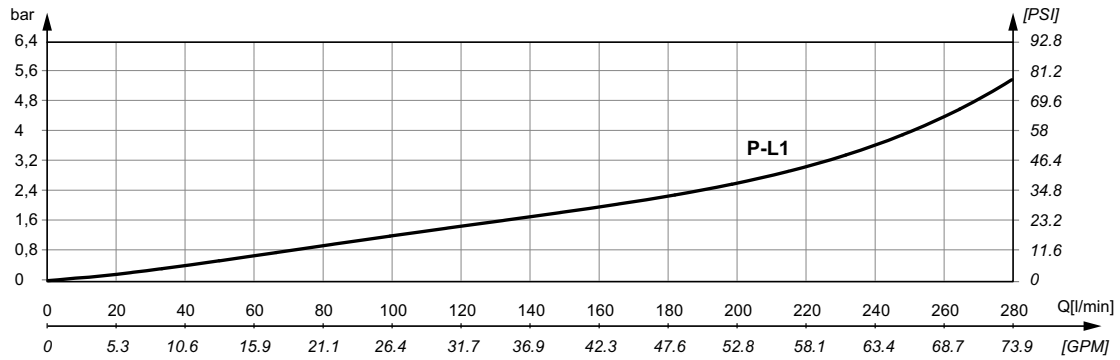

Dimensions

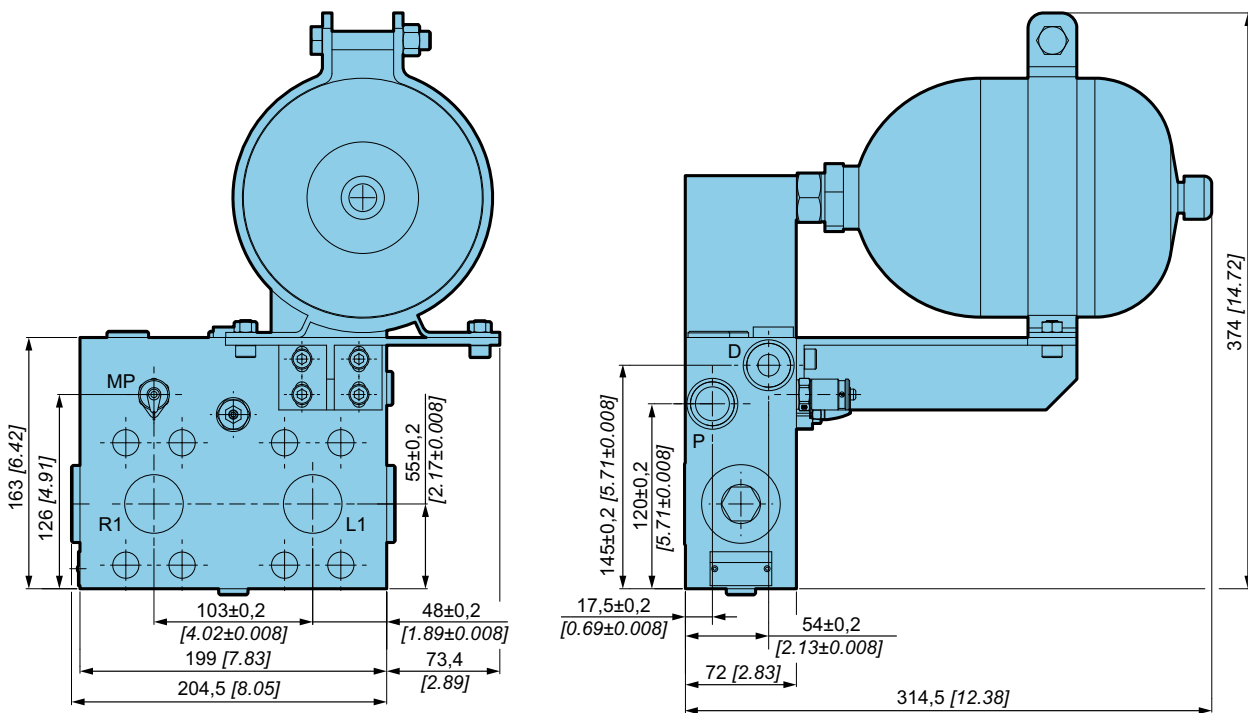

- Model code
- Motors
- Valving systems
- Installation
- Options
- Accessories





Poclain Hydraulics reserves the right to make any modifications it deems necessary to the products described in this document without prior notification. The information contained in this document must be confirmed by Poclain Hydraulics before any order is submitted.

Illustrations are not binding.

The Poclain Hydraulics brand is the property of Poclain Hydraulics S.A.

 26/06/2024

 Not available

 B15766L

 B35256V

 Not available

 Not available

 B54684N

 Not available

 B54783V

