

MS08 - MSE08

HYDRAULIC MOTORS



T E C H N I C A L C A T A L O G



INTRODUCTION

Given their optimized and modular design capable of delivering high performance, motors from the MS Classic range have established themselves as a benchmark on the hydraulic motor market.

MS Classic range can be characterized by:

- **Compactness**
- **Optimized cost**
- **Power density**

The MS HighFlow™ motor range has all the qualities that have made the MS Classic range such a success: they are modular and robust, offering performance advantages (speed and power) at the same time.



MS HighFlow™ motor range is different by:

- **Integrated exchange valve**
- **New ports geometry**
- **New valving**



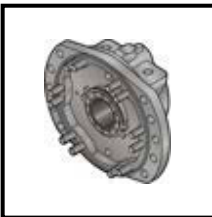
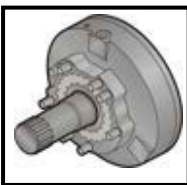
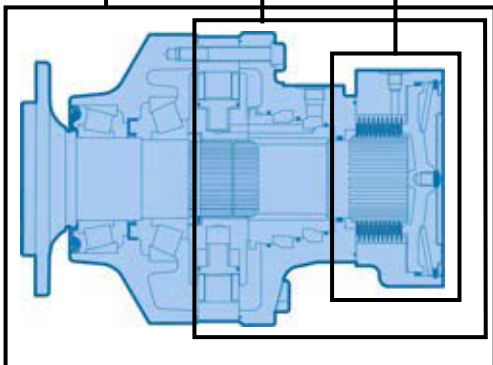

CONTENT

	MODULARITY	6	Modularity and Model code
	MODEL CODE	8	
	WHEEL MOTOR	11	Wheel motor
	Dimensions for Classic (1110) 1-displacement motor	11	
	Dimensions for Classic (1110) 2-displacement motor	12	
	Dimensions for Classic (1110) Twin-Lock™	12	
	Dimensions for Standard (U310) 1-displacement motor	13	
	Dimensions for HighFlow™ (1110) 1-displacement motor	14	
	Dimensions for HighFlow™ (1110) 2-displacement motor	14	
	Dimensions for HighFlow™ (Y610) 2-displacement motor	15	
	Bearing support for Classic and HighFlow™ motor	16	
	Load curves for Classic and HighFlow™ motor	17	
Bearing support for Classic and HighFlow™ motor (continued)	18		
	SHAFT MOTOR	21	Shaft motor
	Dimensions for Classic (2A50) 1-displacement motor	21	
	Dimensions for Classic (2A50) 2-displacement motor	21	
	Dimensions for HighFlow™ (2A50) 1-displacement motor	22	
	Dimensions for HighFlow™ (2A50) 2-displacement motor	22	
	Bearing support for Classic and HighFlow™ motor	23	
	VALVING SYSTEMS AND HYDROBASES	25	Valving systems and hydrobases
	Dimensions for 1-displacement valving	25	
	Cylinder block splines	25	
	Dimensions for other valving systems	26	
	Exchange	28	
	Chassis mountings	28	
	Hydraulic connections	29	
	Efficiency for Classic and HighFlow™ motor	30	
	BRAKES	31	Brake
	Rear brake	31	
	S08™ Service brake	32	
	OPTIONS	33	Options



CHARAC

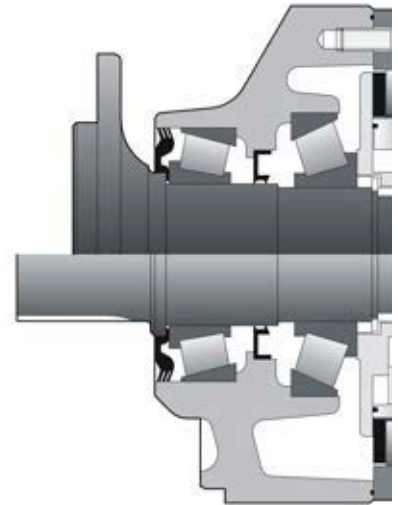

Motor inertia

MS motor working pressure 450 bar [6 526 PSI]
MSE motor working pressure 400 bar [5 801 PSI]

MS08-MSE08 HighFlow™

Max.power	1C motor	41 kW
	2C motor, 1 st displacement	41 kW
	2C motor, 2 nd displacement	27 kW

	C	Motor HighFlow™ 1C		Motor HighFlow™ 2C		
		Max. speed *		Max. speed *		
		1	2	1	2	
		cm³/tr [cu.in./rev.]	cm³/tr [cu.in./rev.]	tr/min[RPM]	tr/min[RPM]	
MS08	Cams with equal lobes	6	467 [28,5]	234 [14,3]	450	420 450
		8	627 [38,2]	314 [19,2]	340	330 350
		9	702 [42,8]	351 [21,4]	310	310 330
		0	780 [47,6]	390 [23,8]	280	260 280
		1	857 [52,3]	429 [26,2]	250	235 260
		2	934 [57,0]	467 [28,5]	230	220 240
		MSE08	Cams with equal lobes	0	1 043 [63,6]	522 [31,8]
1	1 146 [69,9]			573 [34,9]	185	175 200
2	1 248 [76,1]			624 [38,1]	170	160 180
MS08	Cams with unequal lobes	Q	624 [38,1]	< 390 [23,8] 233 [14,2]	294	328 320
		D	700 [42,7]	< 467 [28,5] 233 [14,2]	236	276 259
		A	780 [47,6]	< 467 [28,5] 314 [19,2]	235	271 259
		Q	834 [50,9]	< 522 [31,8] 312 [19,0]	217	243 235
		D	936 [57,1]	< 624 [38,1] 312 [19,0]	171	205 186
		A	1 043 [63,6]	< 624 [38,1] 419 [25,6]	170	200 186

* Based on nominal no-load Δp of 20 bar [290 PSI].



Max. power obtained at max speed, with Peek bushings.

- ① First displacement
- ② Second displacement



TERISTICS

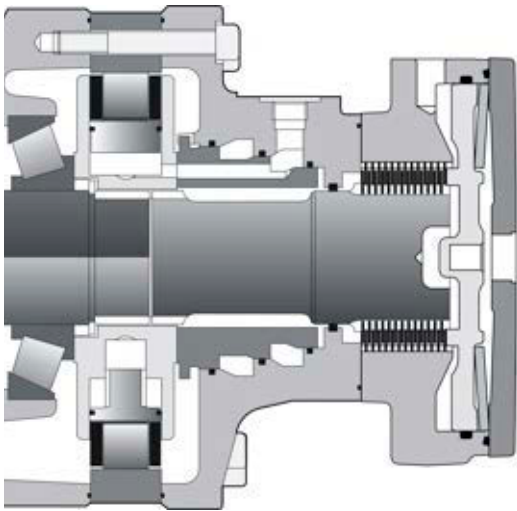

= 0.05 kg.m²

MS motor working pressure 450 bar [6 526 PSI]
 MSE motor working pressure 400 bar [5 801 PSI]

MS08-MSE08 Classic

Max.power	1C motor	41 kW
	2C motor preferred	27 kW
	2C motor non-preferred	21 kW

	C	Cams with equal lobes		Classic motor 1C		Classic motor 2C			
		1	2	1	1 2				
		cm ³ /tr [cu.in/rev.]	cm ³ /tr [cu.in/rev.]	tr/min[RPM]	tr/min[RPM]	tr/min[RPM]			
Cams with equal lobes	MS08	6	467 [28,5]	234 [14,3]	255	235	250		
		8	627 [38,2]	314 [19,2]	200	172	185		
		9	702 [42,8]	351 [21,4]	180	155	165		
		0	780 [47,6]	390 [23,8]	160	130	150		
		1	857 [52,3]	429 [26,2]	145	120	125		
		2	934 [57,0]	467 [28,5]	135	110	115		
	MSE08	0	1 043 [63,6]	522 [31,8]	125	100	110		
		1	1 146 [69,9]	573 [34,9]	110	90	95		
		2	1 248 [76,1]	624 [38,1]	100	80	85		
		Cams with unequal lobes	MS08	Q	624 [38,1]	< 390 [23,8] 233 [14,2]		140	250
				D	700 [42,7]	< 467 [28,5] 233 [14,2]		110	115
			MSE08	A	780 [47,6]	< 467 [28,5] 314 [19,2]		110	110
Q	834 [50,9]			< 522 [31,8] 312 [19,0]		105	110		
D	936 [57,1]			< 624 [38,1] 312 [19,0]		80	85		
A	1 043 [63,6]			< 624 [38,1] 419 [25,6]		80	85		

- ① First displacement
- ② Second displacement

Modularity and Model code

Wheel motor

Shaft motor

Valving systems and hydrobases

Brake

Options



MODUL

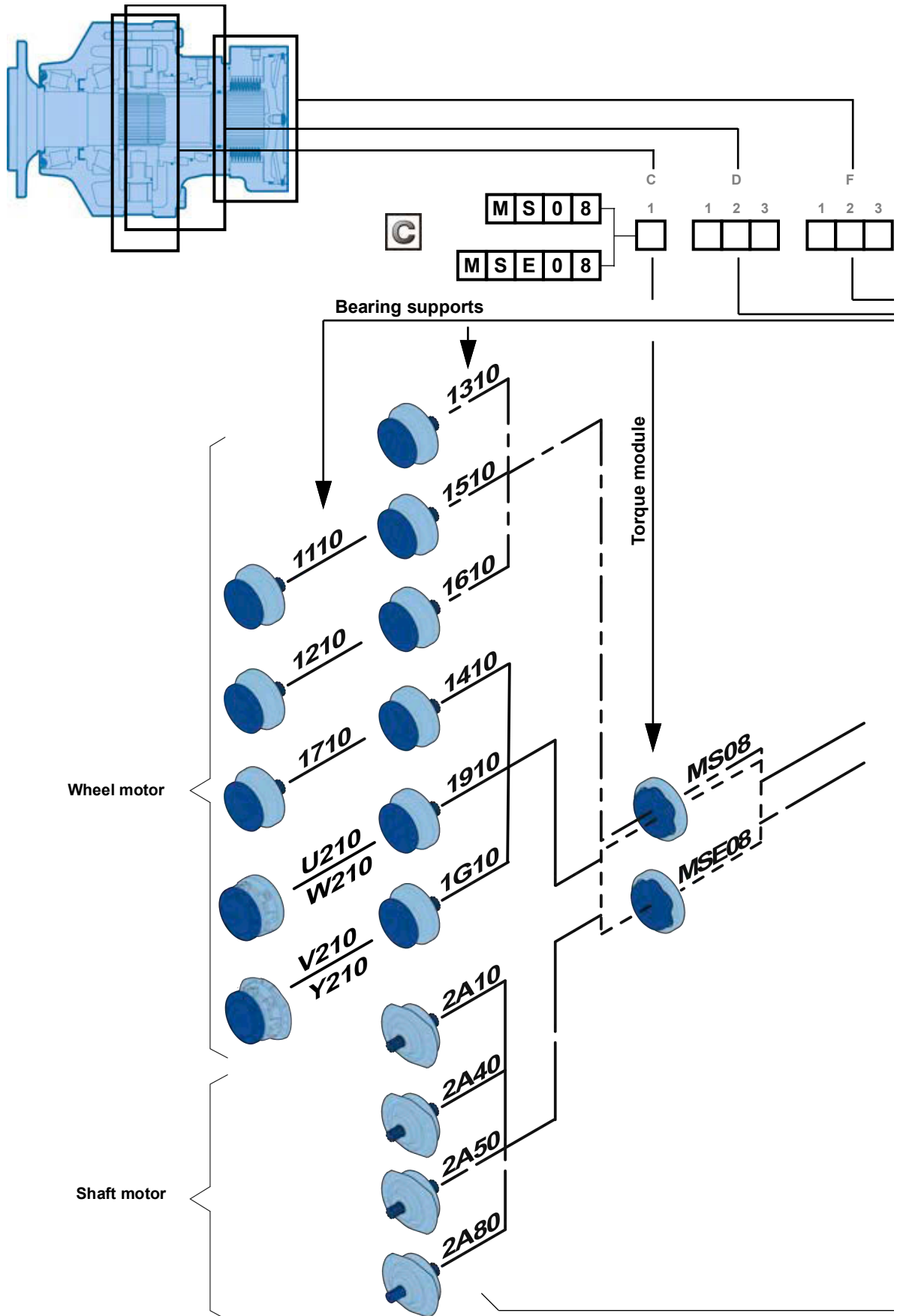



ARITY

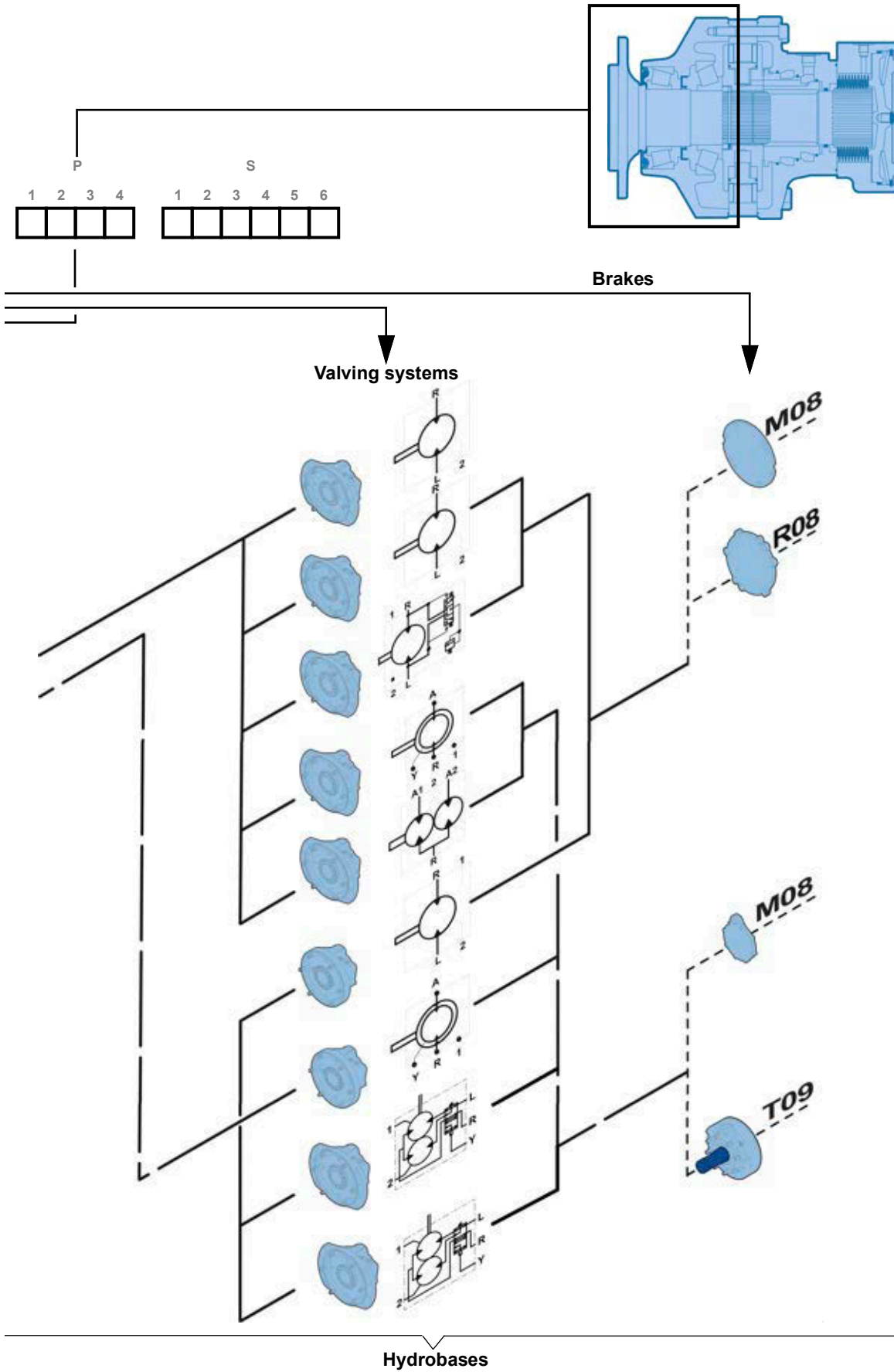

- Modularity and Model code
- Wheel motor
- Shaft motor
- Valving systems and hydrobases
- Brake
- Options



MODEL

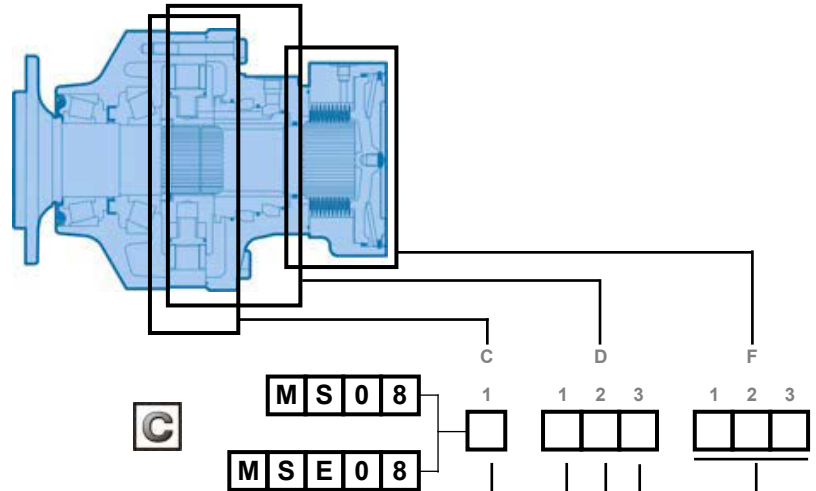

C1

Came type

1 displacement 2 displacements
cm³/tr [cu.in/rev.]

Cams with equal lobes

MS08

467 [28.5]	234 [14.3]	6
627 [38.2]	314 [19.2]	8
702 [42.8]	351 [21.4]	9
780 [47.6]	390 [23.8]	0
857 [52.3]	429 [26.2]	1
934 [57.0]	467 [28.5]	2

MSE08

1 043 [63.6]	522 [31.8]	0
1 146 [69.9]	573 [34.9]	1
1 248 [76.1]	624 [38.1]	2

Cams with unequal lobes

MS08

624 [38.1]	< 390 [23.8]	Q
	233 [14.2]	
700 [42.7]	< 467 [28.5]	D
	233 [14.2]	
780 [47.6]	< 467 [28.5]	A
	314 [19.2]	

MSE08

834 [50.9]	< 522 [31.8]	Q
	312 [19.0]	
936 [57.1]	< 624 [38.1]	D
	312 [19.0]	
1 043 [63.6]	< 624 [38.1]	A
	419 [25.6]	

D1

Valving type

1-displacement valving	1
2-displacement symmetrical valving	A Ratio 2
	B Ratio <2
	C Ratio >2
2-displacement & Twin-Lock™ valving (Clockwise)	D Ratio 2
	E Ratio <2
	F Ratio >2
2-displacement & Twin-Lock™ valving (Counterclockwise)	G Ratio 2
	H Ratio <2
	J Ratio >2

D2

Valving cover

Classic motor	Without mounting	1	4	D
	Lug fixing	2	5	E
HighFlow™ motor	Without mounting	B	L	-
	Lug fixing	C	N	-

1 Displacement
2 Displacement
Exchange
Twin-Lock™

D3

Connection type

ISO 6162 Flanges	DN13	1
ISO 9974-1 connections		
ISO 6162 Flanges	DN13	2
ISO 1179-1 connections		
ISO 1179-1 connections	G3/4	3
ISO 9974-1 connections	M22 x 1.5	4
ISO 9974-1 connections	M27 x 2	5
ISO 6149-1 connections	M22 x 1.5	8
ISO 11 926-1 connections	1" 1/16 - 12 UNF	A

F1-F3

Rear brake

One-piece valving cover single displacement	M 0 8		
Without brake (reinforced plate)	R 0 8		
Brake	Parking brake	Screwed enviromental cover	T 0 9



CODE

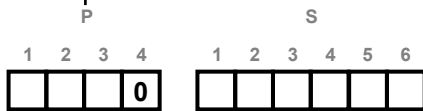
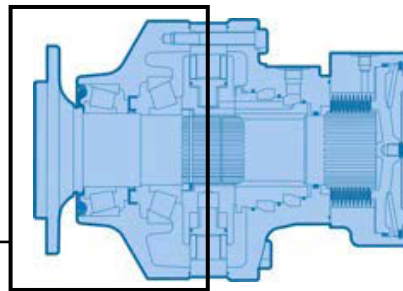

P1 Front unit

0	Without bearing support	
1	Without mounting	
2	Lug mounting	
U	valving cover fixation	single control command
V	chassis fixation	
W	valving cover fixation	double control command
Y	chassis fixation	

P3 Shaft type

1	Without studs
2	With studs + nuts
3	With studs
4	M threaded holes

Male shafts

1	NF E22-141 splines
4	Cylindrical with key
5	DIN 5480 splines
8	ANSI B92.1 - 1996 splines

P2 Bearing support

0	Without shaft
1	6 x Ø20 on Ø205
2	8 x Ø22 on Ø203.2
3	6 x Ø20 on Ø205
4	10 x Ø18 on Ø225
5	6 x Ø18 on Ø152.4
6	12 x M12 on Ø205
7	8 x Ø22 on Ø275
9	12 x Ø14 on Ø165
G	Support without drum brake
A	For male shaft bearing support

S1-S6 Options

0	Without option
1	Fluorinated elastomer seals compatible with C and D fluids
2	T4 speed sensor (without rotation direction)
3	Brake environmental cover without plug
5	Drainage (additional drain in the cover)
6	Industrial bearing support
7	Diamond™
8	Predisposition for speed sensor
A	Hollow shaft
B	Drain on the bearing support
C	Abrasive environment (mechanical seal)
D	Special paint or no paint
E	Reinforced sealing
G	Special wheel rim mounting
H	High efficiency
J	Surface heat treatment of the shaft
M	High speed
Q	TD speed sensor (two phase shifted frequencies)
S	TR speed sensor (digital rotation direction)

Modularity and Model code

Wheel motor

Shaft motor

Valving systems and hydrobases

Brake

Options



Methodology :

This document is intended for manufacturers of machines that incorporate Poclain Hydraulics products. It describes the technical characteristics of Poclain Hydraulics products and specifies installation conditions that will ensure optimum operation. This document includes important comments concerning safety. They are indicated in the following way:



Safety comment.

This document also includes essential operating instructions for the product and general information. These are indicated in the following way:



Essential instructions.



General information.



Information on the model number.



Weight of component without oil.



Volume of oil.



Units.



Tightening torque.



Screws.



Information intended for Poclain-Hydraulics personnel.

The views in this document are created using metric standards.
The dimensional data is given in mm and in inches (inches are given in brackets in italics).





WHEEL MOTOR CLASSIC

Dimensions for Classic (1110) 1-displacement motor

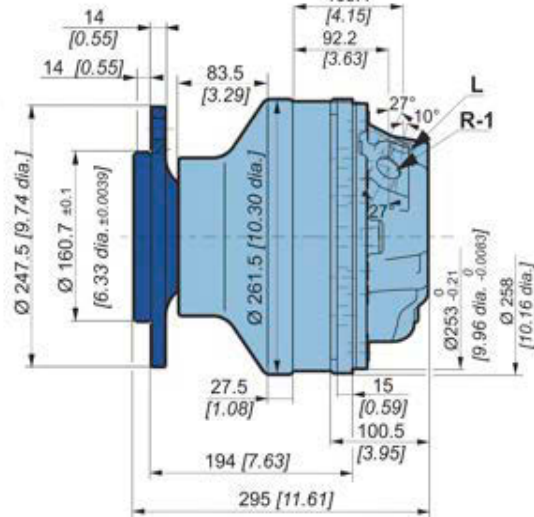
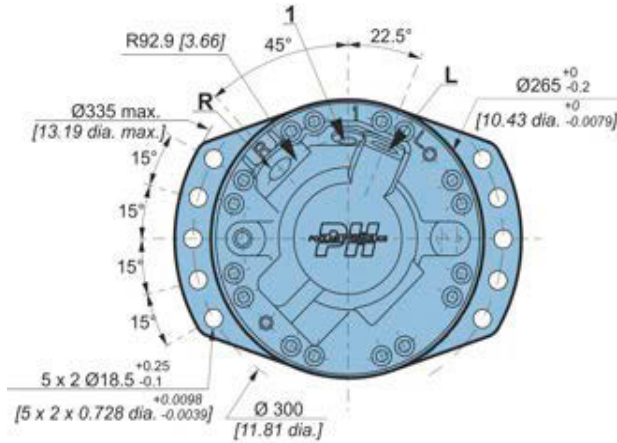

	60 kg [132 lb]	79 kg [174 lb]
	1.50 L [90 cu.in.]	1.00 L [60 cu.in.]

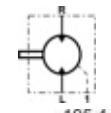

Modularity and Model code

Wheel motor

Shaft motor

Dimensions for Classic (1110) 1-displacement motor

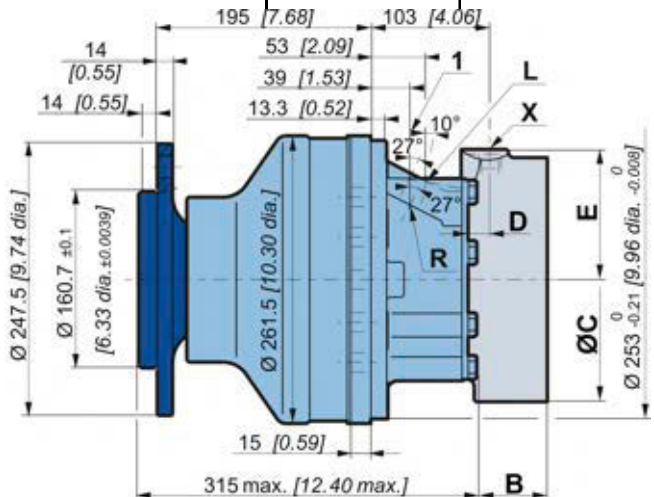
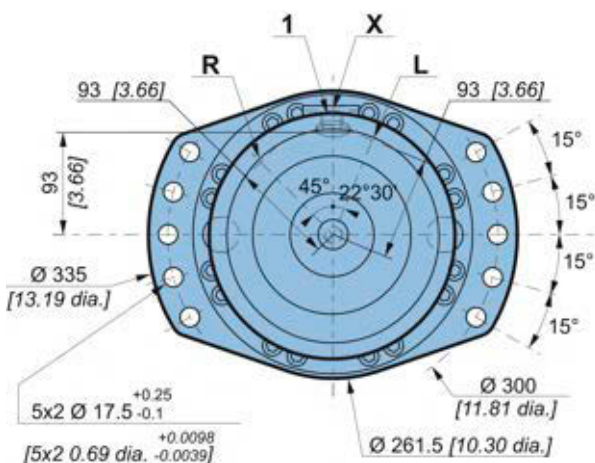

	60 kg [132 lb]	79 kg [174 lb]
	1.50 L [90 cu.in.]	1.00 L [60 cu.in.]

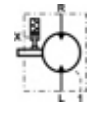
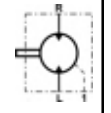

Valving systems and hydrobases

Brake

Options

	C	T 0 9
	B	87.10 [3.43]
	C	Ø255 [10.02 dia.]
	D	19.0 [0.75]
	E	115.0 [4.53]

Also see "Brake" section (thumbnail opposite).

Also see 'Valving systems and hydrobases' section (thumbnail opposite).



Dimensions for Classic (1110) 2-displacement motor

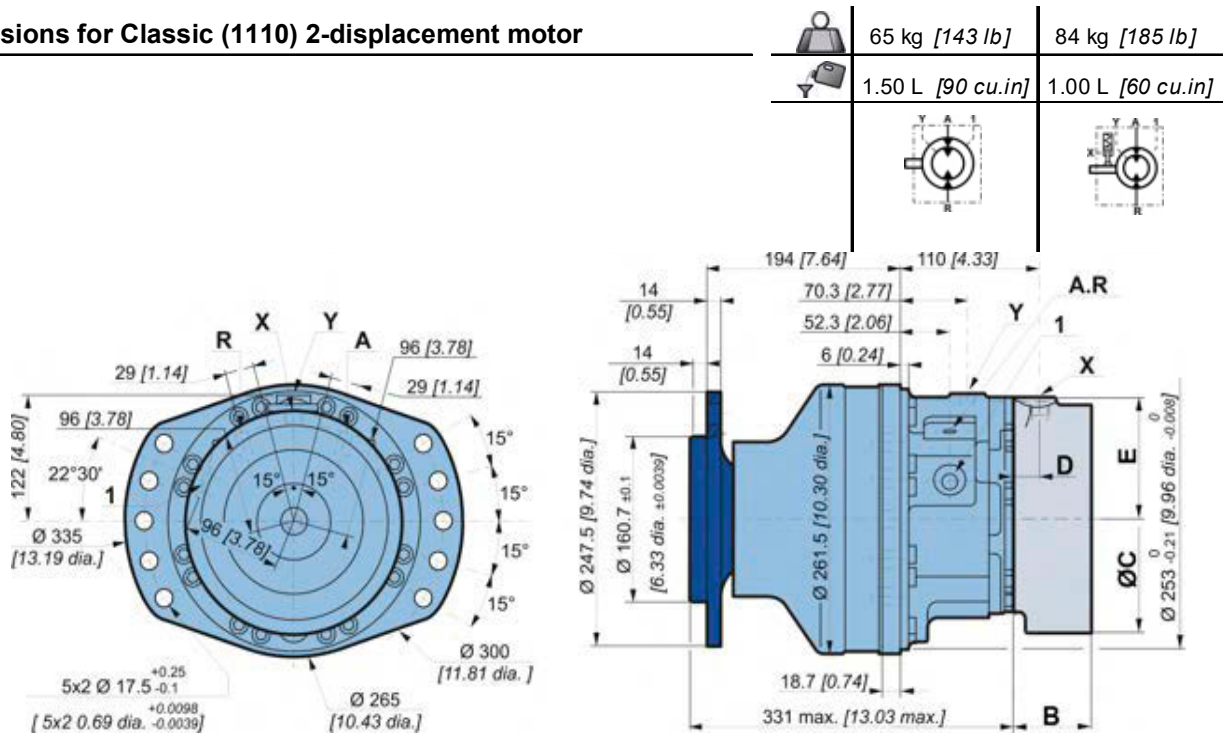

Dimensions for Classic (1110) Twin-Lock™

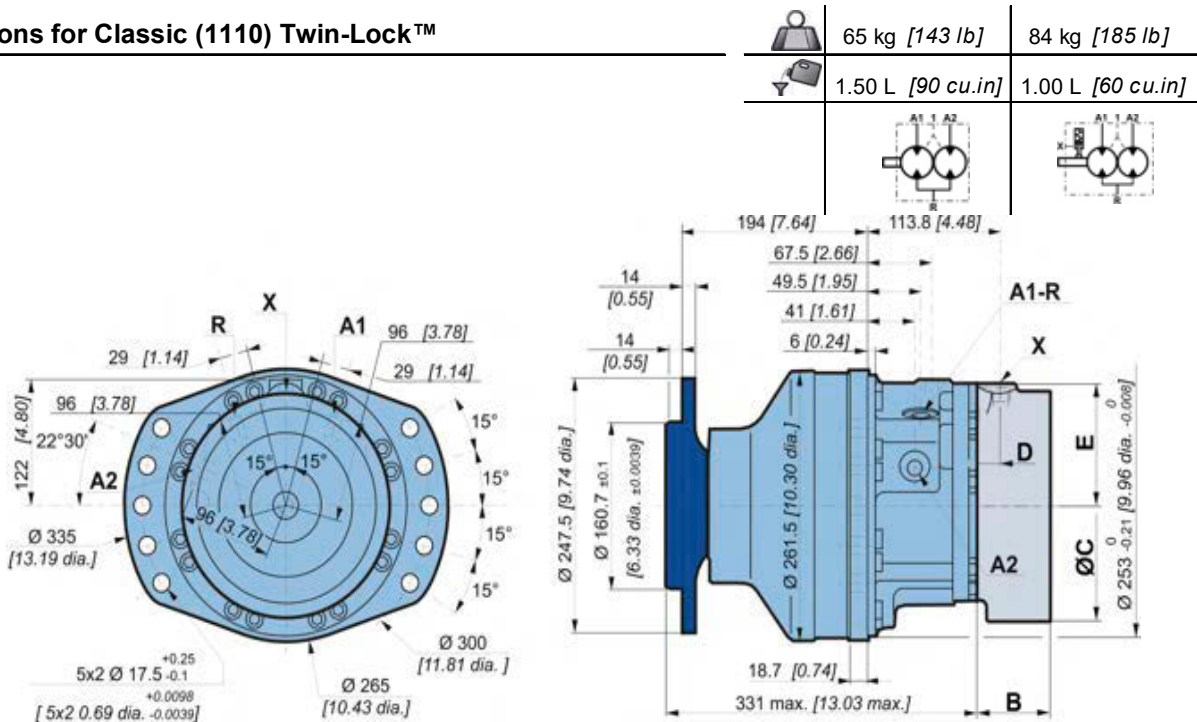

	C	T 0 9
	B	87.10 [3.43]
	C	Ø255 [10.02 dia.]
	D	19.0 [0.75]
	E	115.0 [4.53]

Also see "Brake" section (thumbnail opposite).

Also see 'Valving systems and hydrobases' section (thumbnail opposite).



Dimensions for Standard (U310) 1-displacement motor



75 kg [165 lb]

1.10 L [66 cu.in.]

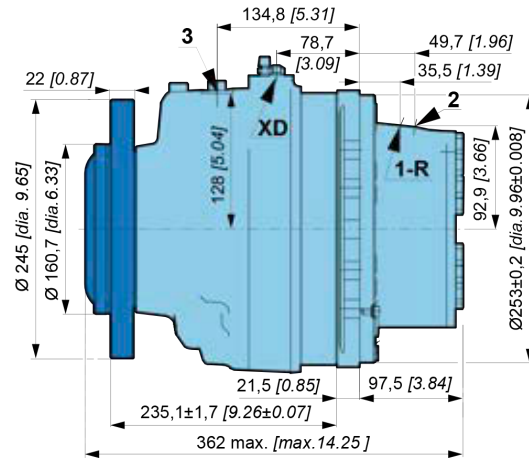
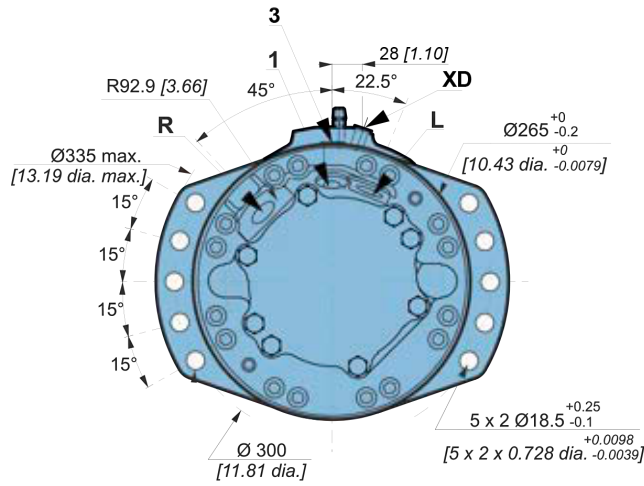
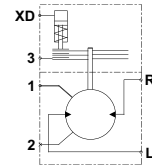

Modularity and Model code

Wheel motor

Shaft motor

Valving systems and hydrobases

Brake

Options



WHEEL MOTOR HIGHFLOW™

Dimensions for HighFlow™ (1110) 1-displacement motor

	60 kg [132 lb]	79 kg [174 lb]
	1.50 L [90 cu.in.]	1.00 L [60 cu.in.]

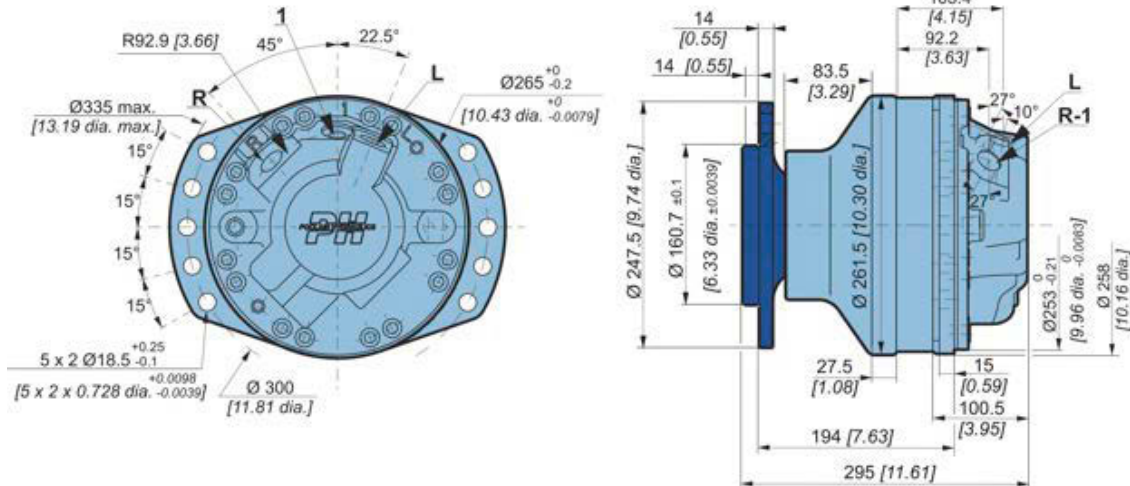

Dimensions for HighFlow™ (1110) 2-displacement motor

	60 kg [132 lb]	79 kg [174 lb]
	1.50 L [90 cu.in.]	1.00 L [60 cu.in.]

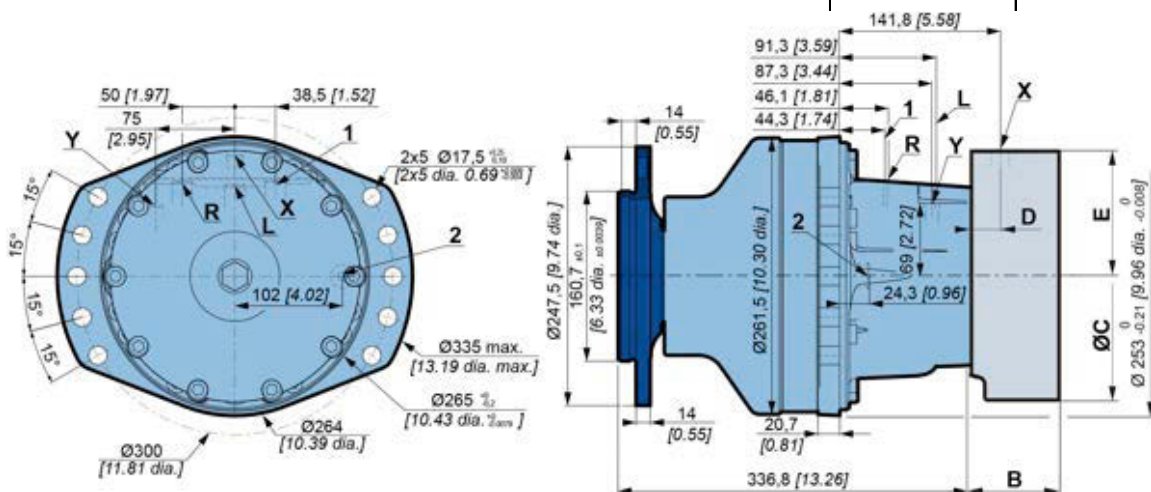

	T 0 9
B	88,2 [3,47]
C	Ø238 [9,37 dia.]
D	21,0 [0,83]
E	114,0 [4,49]



Also see "Brake" section (thumbnail opposite).



Also see 'Valving systems and hydrobases' section (thumbnail opposite).



Dimensions for HighFlow™ (Y610) 2-displacement motor



75 kg [165 lb]

1.10 L [66 cu.in.]

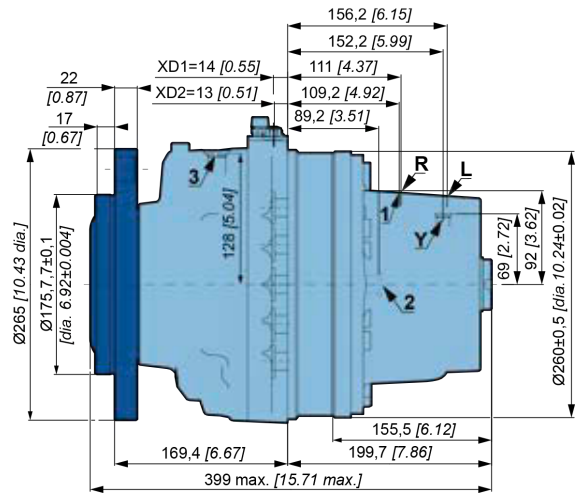
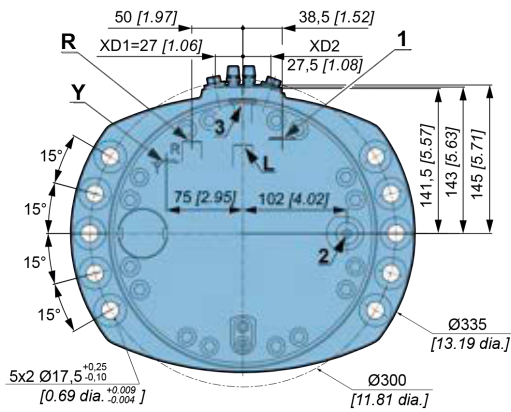
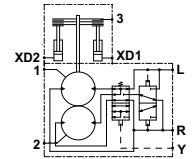

Modularity and Model code

Wheel motor

Shaft motor

Valving systems and hydrobases

Brake

Options



Bearing support for Classic and HighFlow™ motor

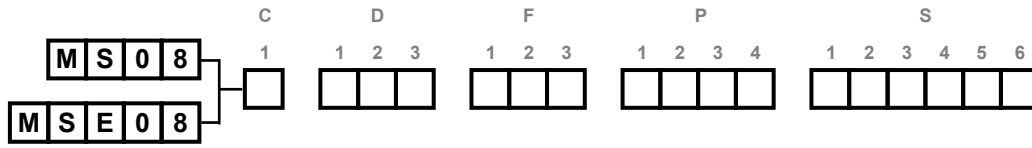

C	A mm [in.]	B mm [in.]	C mm [in.]	D mm [in.]	E mm [in.]	N mm [in.]	Wheel rim mountings	L mm [in.]
	Ø 160.7 [6.33 dia.]	Ø 205 [8.07 dia.]	Ø 245 [9.65 dia.]	195 [7.68]	Ø 261.5 [10.30 dia.]	6 x Ø 20 [6 x 0.79 dia.]	M18x1.5	13.5 [0.53]
	Ø 150.9 [5.94 dia.]	Ø 203.2 [8.00 dia.]	Ø 238 [9.37 dia.]	194.1 [7.64]	Ø 261.5 [10.30 dia.]	8 x Ø 22 [8 x 0.87 dia.]	M20x1.5	13.5 [0.53]
	Ø 175.7 [6.92 dia.]	Ø 225 [8.86 dia.]	Ø 270 [10.63 dia.]	188.8 [7.43]	Ø 261.5 [10.30 dia.]	10 x Ø 18 [10 x 0.71 dia.]	M16x1.5	15 [0.59]
	Ø 160.7 [6.33 dia.]	Ø 205 [8.07 dia.]	Ø 245 [9.65 dia.]	163 [6.42]	Ø 261.5 [10.30 dia.]	6 x Ø 20 [6 x 0.79 dia.]	M18x1.5	14 [0.55]
	Ø 117.5 [4.63 dia.]	Ø 152.4 [6.00 dia.]	Ø 181 [7.13 dia.]	163 [6.42]	Ø 261.5 [10.30 dia.]	6 x Ø 18 [6 x 0.71 dia.]	M14x1.5	11 [0.43]
	Ø 160.7 [6.33 dia.]	Ø 205 [8.07 dia.]	Ø 245 [9.65 dia.]	163 [6.42]	Ø 261.5 [10.30 dia.]	12 x M12	-	14.8 [0.58]

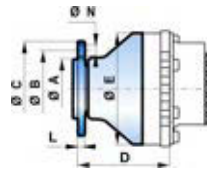
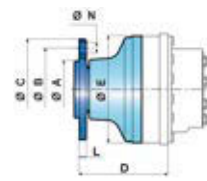

The supports in gray must not be assembled with an MSE hydrobase.



Load curves for Classic and HighFlow™ motor

Permissible radial loads

Test conditions :

Static : 0 tr/min [0 RPM] 0 bar [0 PSI]

Dynamic : 0 tr/min [0 RPM], code 0 displacement, without axial load at max. torque

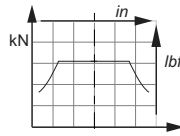

Service life of bearings

Test conditions :

L : Millions B10 revolutions at 150 bars (average pressure), with 25 cSt fluid, code 0 displacement, without axial load.

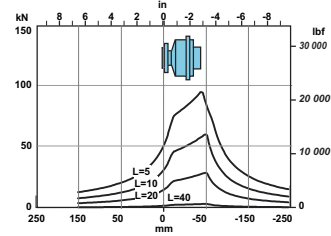
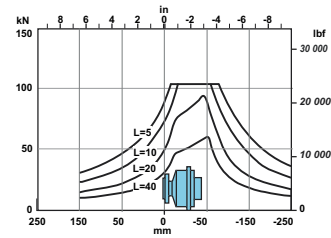
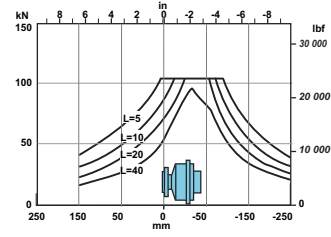
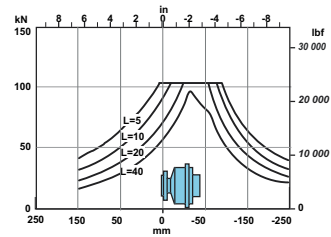
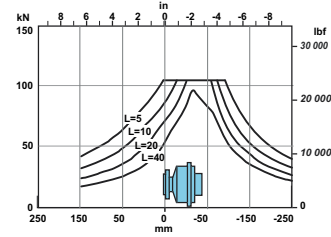
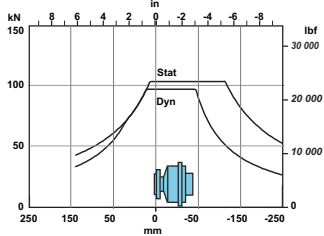
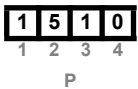
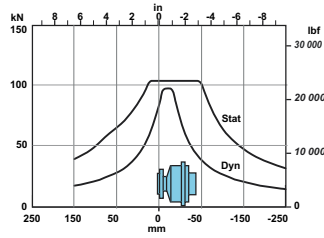
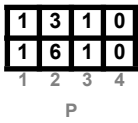
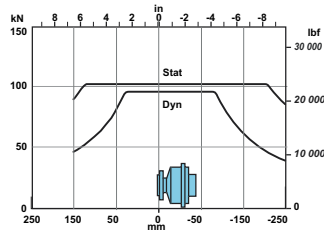
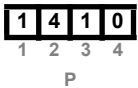
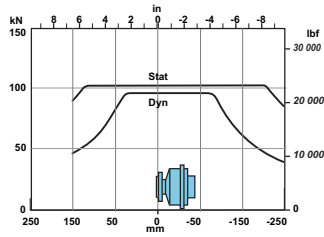
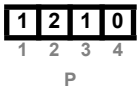
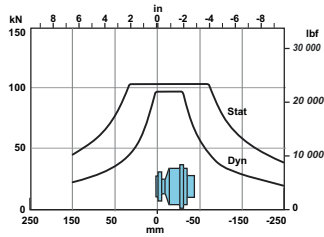
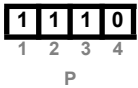

Modularity and Model code

Wheel motor

Shaft motor

Valving systems and hydrobases

Brake

Options



The service life of the components is influenced by the pressure. You must check that the combination of forces applied (Axial load / Radial load) is compatible with the permissible loads for the components, and that the resulting service lives of these components complies with the application's specifications. For an accurate calculation, consult your Poclain Hydraulics application engineer.

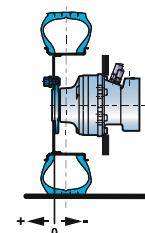



Bearing support for Classic and HighFlow™ motor (continued)

C	MS08				D			F			P				S					
	1	1	2	3	1	2	3	1	2	3	1	2	3	4	1	2	3	4	5	6
C	A	B	C	D	E	N	Wheel rim mountings	L												
mm [in]	mm [in]	mm [in]	mm [in]	mm [in]	mm [in]	mm [in]		mm [in]												
1 9 1 0 1 2 3 4 P	Ø 117.5 [4.63 dia.]	Ø 165 [6.50 dia.]	Ø 186 [7.32 dia.]	163.2 [6.43]	Ø 261.5 [10.30 dia.]	12 x Ø 14 [12 x 0.55 dia.]	-	12 [0.47]												
1 G 1 0 1 2 3 4 P	Ø 175.7 [6.92 dia.]	Ø 225 [8.86 dia.]	Ø 265 [10.43 dia.]	228.6 [9.00]	Ø 261.5 [10.30 dia.]	10 x Ø 24 [10 x 0.94 dia.]	M22x1.5	15 [0.59]												
1 7 1 0 1 2 3 4 P	Ø 220.7 [8.69 dia.]	Ø 275 [10.83 dia.]	Ø 314 [12.36 dia.]	194 [7.64]	Ø 261.5 [10.30 dia.]	8 x Ø 22 [8 x 0.87 dia.]	M20x1.5	14 [0.55]												
U 3 1 0 W 3 1 0 1 2 3 4 P	Ø 160.7 [6.33 dia.]	Ø 205 [8.07 dia.]	Ø 245 [9.65 dia.]	235.0 [9.25]	Ø 267.0 [10.51 dia.]	6 x Ø 20 [6 x 0.79 dia.]	6 x M18x1.5	22 [0.87]												
V 3 1 0 Y 3 1 0 1 2 3 4 P	Ø 160.7 [6.33 dia.]	Ø 205 [8.07 dia.]	Ø 245 [9.65 dia.]	169.4 [6.67]	Ø 267.0 [10.51 dia.]	6 x Ø 20 [6 x 0.79 dia.]	6 x M18x1.5	22 [0.87]												

Studs

	P	C min.	C max.	D	Class	
						mm [in]
Various studs	M14x1.5	45 [1,77]	5 [0,20]	15 [0,57]	16,5 [0,65]	12,9
	M18x1.5	55 [2,17]		18 [0,71]	23 [0,91]	
	M18x1.5	65 [2,56]		23 [0,91]	25 [0,98]	
	M20x1.5	60 [2,36]		21 [0,83]	25 [0,98]	
	M22x1.5	55 [2,17]		15 [0,59]	26 [1,02]	
	M22x1.5	80 [3,15]		40 [1,57]		
Screws	M12x1.75	-	-			10,9
	1/2"-20 UNF	-	-			10,9



See generic installation motors N°B59689D.



Load curves for Classic and HighFlow™ motor (continued)

Permissible radial loads

Test conditions :

Static : 0 tr/min [0 RPM] 0 bar [0 PSI]

Dynamic : 0 tr/min [0 RPM], code 0 displacement, without axial load at max. torque

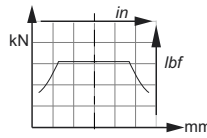

Service life of bearings

Test conditions :

L : Millions B10 revolutions at 150 bars (average pressure), with 25 cSt fluid, code 0 displacement, without axial load.

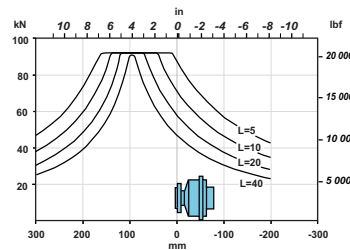
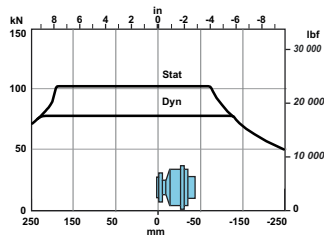
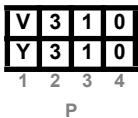
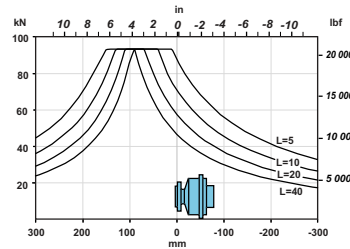
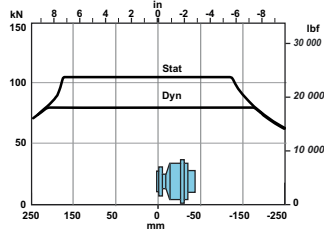
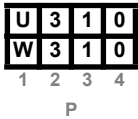
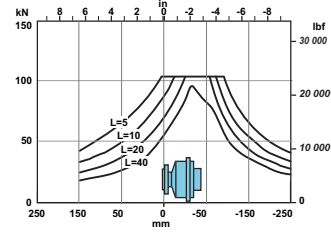
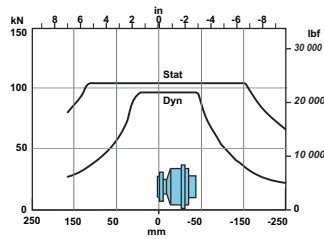
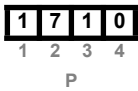
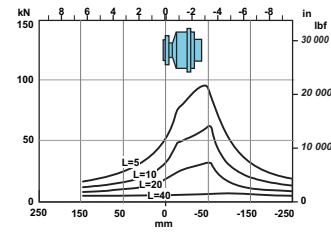
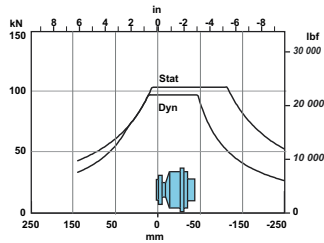
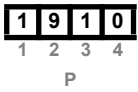

The service life of the components is influenced by the pressure. You must check that the combination of forces applied (Axial load / Radial load) is compatible with the permissible loads for the components, and that the resulting service lives of these components complies with the application's specifications. For an accurate calculation, consult your Poclain Hydraulics application engineer.

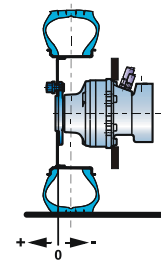

Modularity and Model code

Wheel motor

Shaft motor

Valving systems and hydrobases

Brake

Options





SHAFT MOTOR CLASSIC

Dimensions for Classic (2A50) 1-displacement motor

	62 kg [136 lb]	80 kg [176 lb]
	1.50 L [90 cu.in]	1.00 L [60 cu.in]

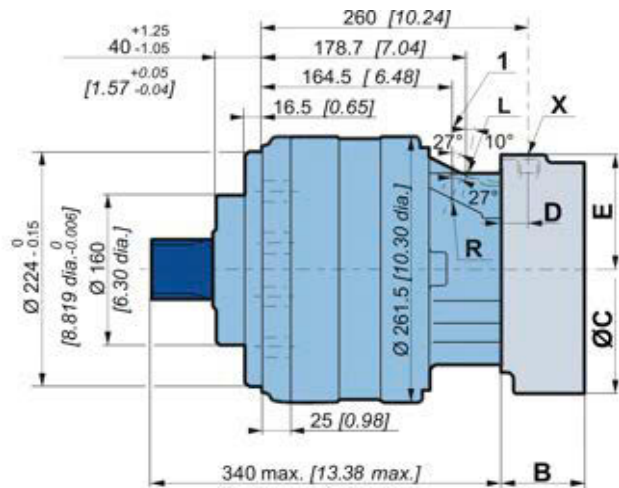
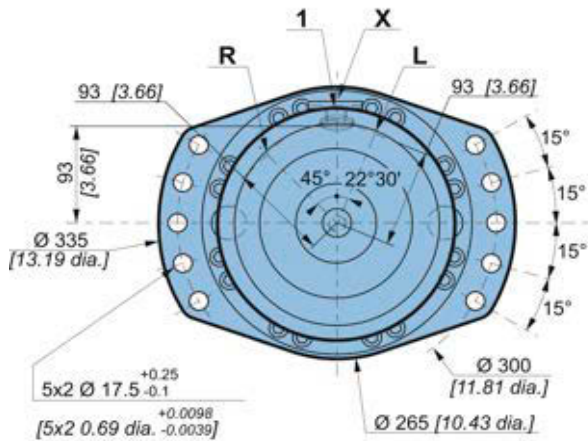

Dimensions for Classic (2A50) 2-displacement motor

	67 kg [147 lb]	85 kg [187 lb]
	1.50 L [90 cu.in]	1.00 L [60 cu.in]

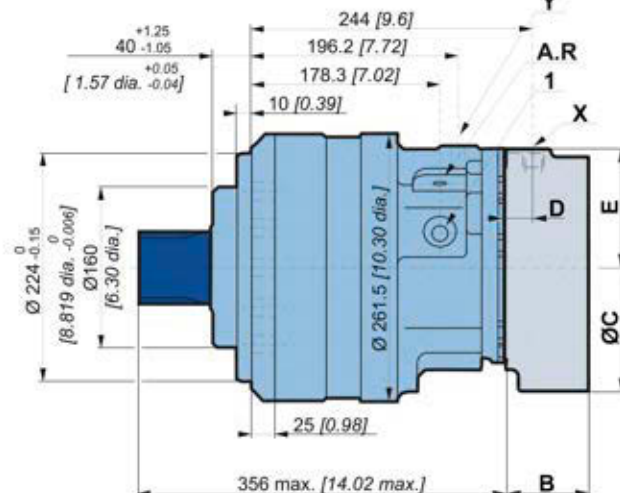
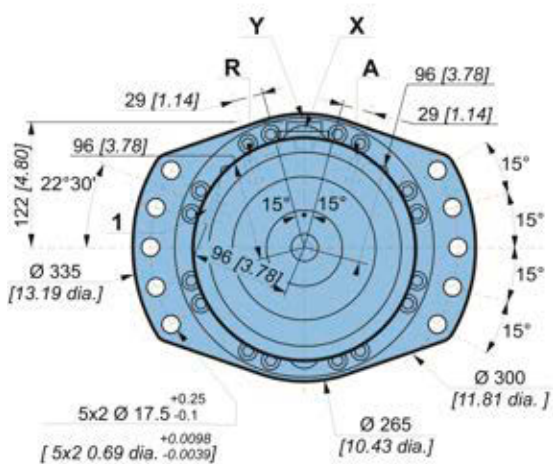

	C	T 0 9
	B	87.10 [3.43]
	C	Ø255 [10.02 dia.]
	D	19.0 [0.75]
	E	115.0 [4.53]



Also see "Brake" section (thumbnail opposite).



Also see 'Valving systems and hydrobases' section (thumbnail opposite).

Modularity and Model code

Wheel motor

Shaft motor

Valving systems and hydrobases

Brake

Options



SHAFT MOTOR HIGHFLOW™

Dimensions for HighFlow™ (2A50) 1-displacement motor

	62 kg [136 lb]	80 kg [176 lb]
	1.50 L [90 cu.in]	1.00 L [60 cu.in]

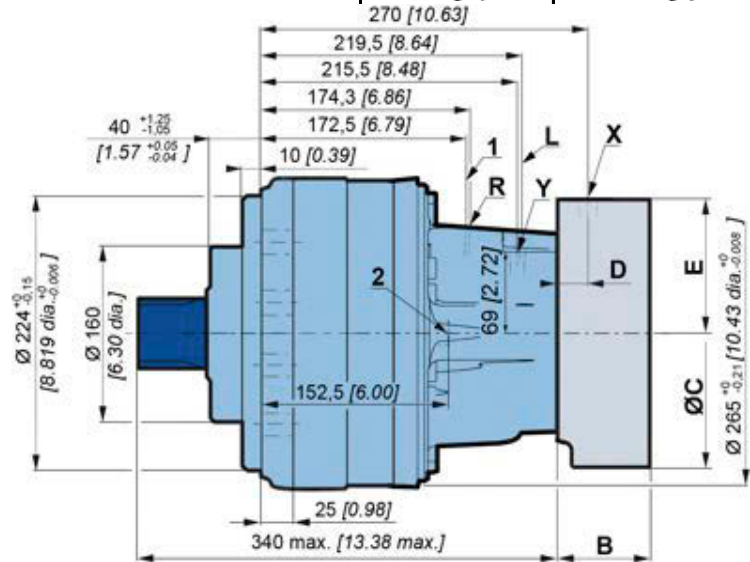
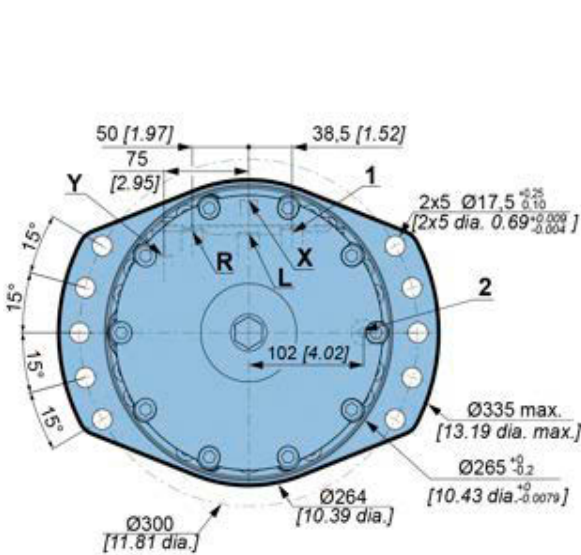

Dimensions for HighFlow™ (2A50) 2-displacement motor

	67 kg [147 lb]	85 kg [187 lb]
	1.50 L [90 cu.in]	1.00 L [60 cu.in]

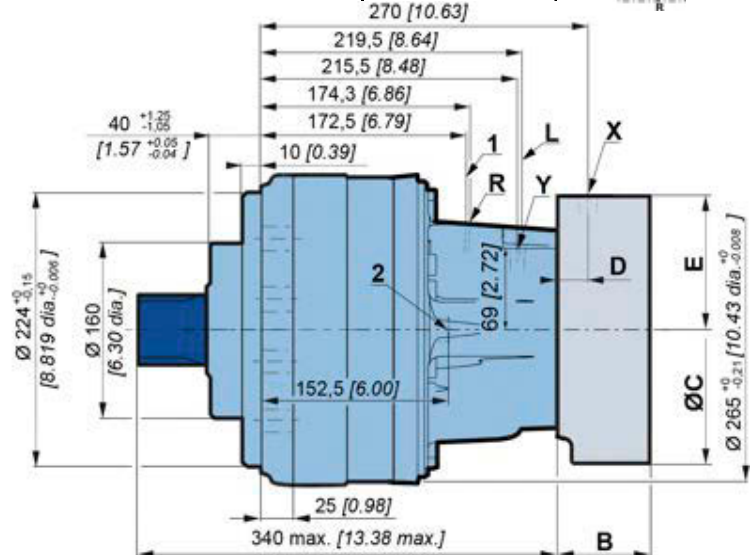
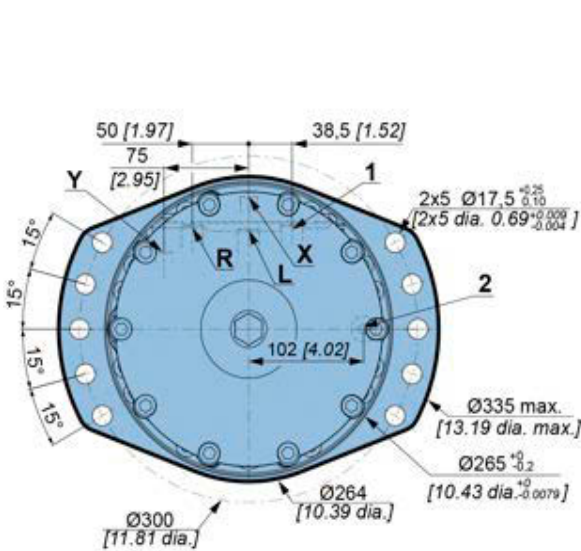

	C	T 0 9
	B	88,2 [3,47]
	C	Ø238 [9,37 dia.]
	D	21,0 [0,83]
	E	114,0 [4,49]



Also see "Brake" section (thumbnail opposite).



Also see 'Valving systems and hydrobases' section (thumbnail opposite).



Bearing support for Classic and HighFlow™ motor

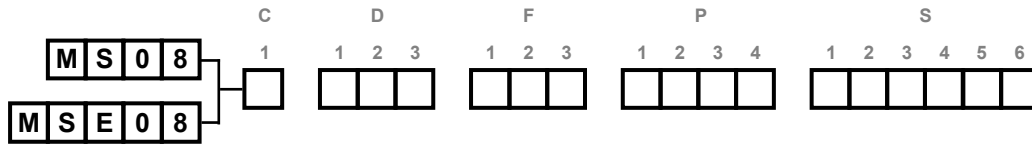

C		A	B	C	D	E	F			
NF E22-141 splines										
2	A 1 0	Nominal Ø	65 [2.56]	15	R 2.5	35	2 x M10		24	70
Module		2.5		[0.59]		[R 0.10]			[1.38]	
Z		24		[0.94]		[2.76]				
DIN 5480 splines										
2	A 5 0	Nominal Ø	70 [2.76]	15	R 2.5	35	2 x M10		23	70
Module		3		[0.59]		[R 0.10]			[1.38]	
Z		22		[0.91]		[2.76]				
ANSI B92.1 - 1996 splines										
2	A 8 0	Nominal Ø	74.5 [2.93]	35	R 2.8	74.5	M12		23	70
Module		16/32		[1.38]		[R 0.11]			[2.93]	
Z		46		[0.91]		[2.76]				
DIN 6885 Key										
2	A 4 0	X 20	[0.79]	30	R 2.5	Ø 69.99	M16		90	106
Y 74		max. [2.91]		[1.18]		[0.10 R.]			[2.76 dia.]	
Z								[3.54]		[4.17]

Modularity and Model code

Wheel motor

Shaft motor



Also see 'Valving systems and hydrobases' section (thumbnail opposite).

Splined coupling

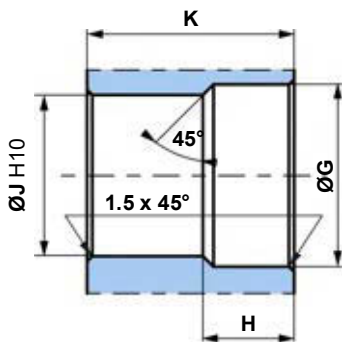

Standard NF E22-141
 Pressure angle 20°.
 Centering on flanks.
 Slide fit (7H quality).

Standard DIN 5480, ANSI B92.1-1996
 Pressure angle 30°.
 Centering on flanks.
 Slide fit (7H quality).

N : Nominal Ø.
Mo : Module.
Z : Number of teeth.

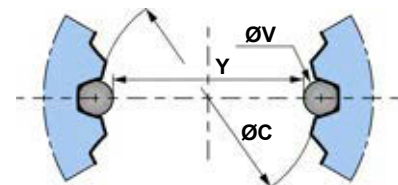

Valving systems and hydrobases

Brake

C	Ø G	H	Ø J	K	N	Mo	Z	Offset	Ø C (H10)	Ø V	Y	Tolerance µm [µin]
2 A 1 0	66 [2.60]	25 [0.98]	60 [2.36]	69 [2.72]	65 [2.56]	2.5	24	2 [0.08]	60 [2.36]	5 [0.20]	55.169 [2.17]	+ 86 / 0 [+3.386 / 0]
2 A 5 0	71.5 [2.81]	25 [0.98]	64 [2.52]	69 [2.72]	70.0 [2.76]	3	22	+0.35 [+0.0138]	64.0 [2.52]	5.25 [0.21]	59.042 [2.32]	+ 76 / +28 [+2.992 / +1.1]
2 A 8 0	76.0 [2.99]	24 [0.94]	71.438 [2.81]	69 [2.72]	63.242 [2.49]	16/32	46	-	71.438 [2.81]	2.743 [0.11]	69.201 [2.72]	+ 32 / -32 [+2.992 / +1.1]

Options

General tolerances : ± 0.25 [±0.0098].

Material: Ex: 42CrMo4.

Hardening treatment to obtain R = 800 to 900 N/mm² [R = 116 030 to 130 533 PSI].



Load curves for Classic and HighFlow™ motor

Permissible radial loads

Max. permissible loads: 0 tr/min [0 RPM]; 0 bar [0 PSI]

Continuous permissible loads:

> 0 tr/min [> 0 RPM]; 275 bar [3 988 PSI].

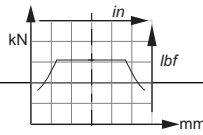

Service life of bearings

Test conditions :

L : Millions B10 revolutions at 150 bars (average pressure), with 25 cSt fluid, code 0 displacement, without axial load.

2 A 1 0
1 2 3 4
P

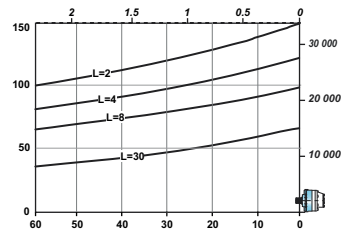
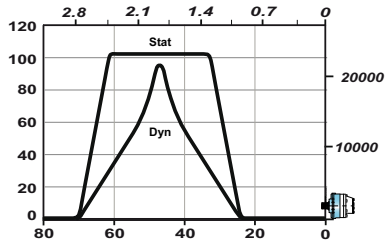

2 A 5 0
1 2 3 4
P

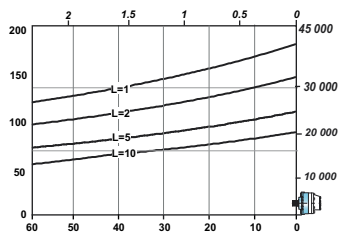
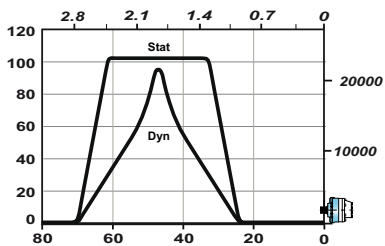

The service life of the components is influenced by the pressure. You must check that the combination of forces applied (Axial load / Radial load) is compatible with the permissible loads for the components, and that the resulting service lives of these components complies with the application's specifications. For an accurate calculation, consult your Poclain Hydraulics application engineer.

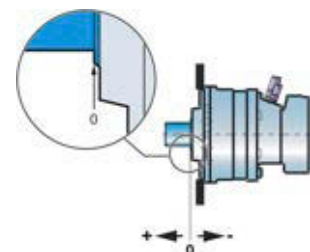



VALVING SYSTEMS AND HYDROBASES

for Classic motor on demand for HighFlow™ motor

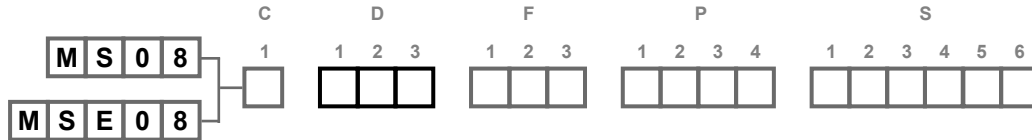

Dimensions for 1-displacement valving

	34.4 kg [76 lb]	51.8 kg [114 lb]
	0.50 L [30 cu.in]	1.00 L [60 cu.in]

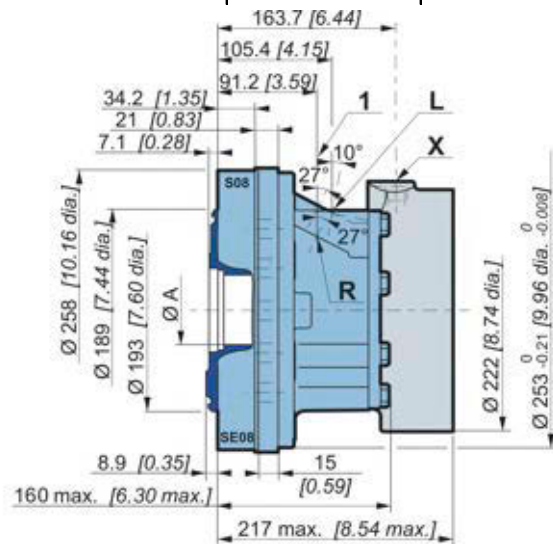
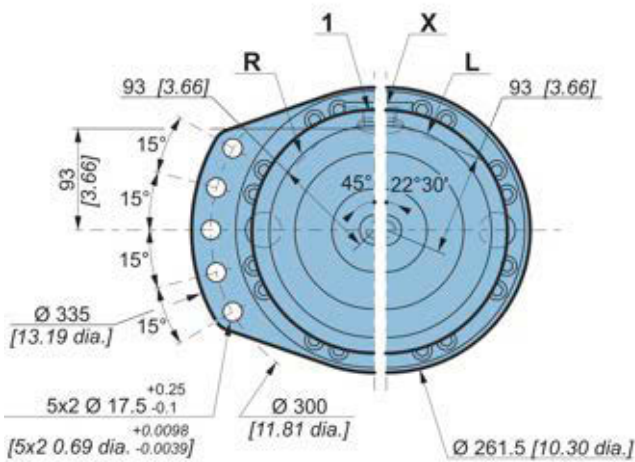

Cylinder block splines

(as per standard NF E22-141)

ØA	Module	Z	Dimension on 2 pins	
			Y	ØV
60 [2.362]	2.5	24	69.580 [2.739]	4.5 [0.177]

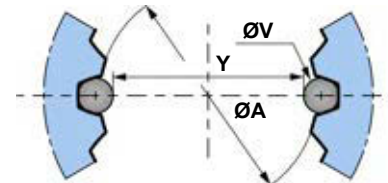

You are advised to have the installation validated by your Poclain Hydraulics application engineer before using the hydraulic unit in an application.



We must provide you with a detailed plan of the interface for any hydraulic unit use, consult your Poclain Hydraulics sales engineer.

Modularity and Model code

Wheel motor

Shaft motor

Valving systems and hydrobases

Brake

Options



Dimensions for one-piece valving single displacement

	35 kg [77 lb]
	0.50 L [30 cu.in]

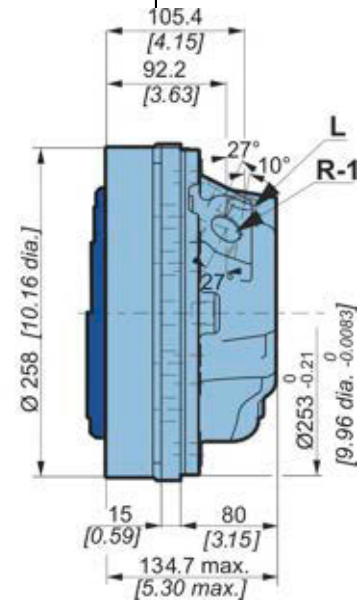
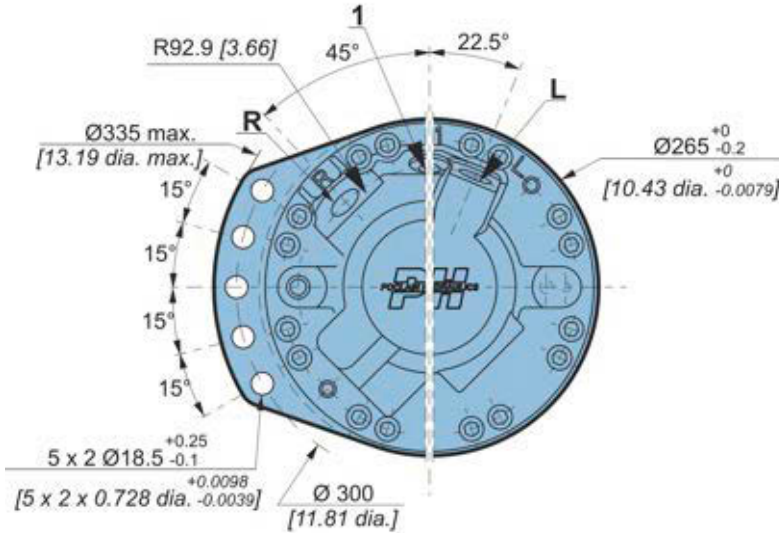
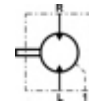

Dimensions for 2-displacement valving

	37.8 kg [83 lb]	54.7 kg [120 lb]
	0.50 L [30 cu.in]	1.00 L [60 cu.in]

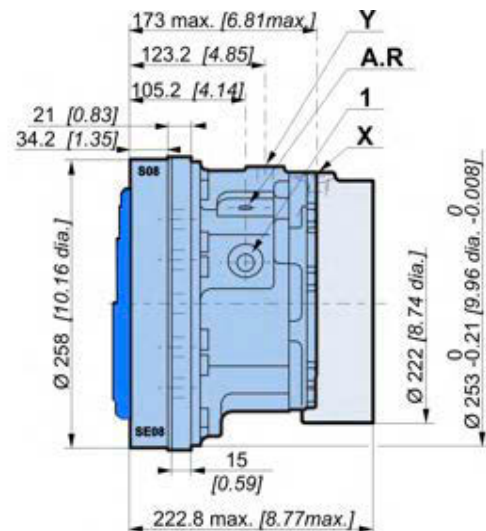
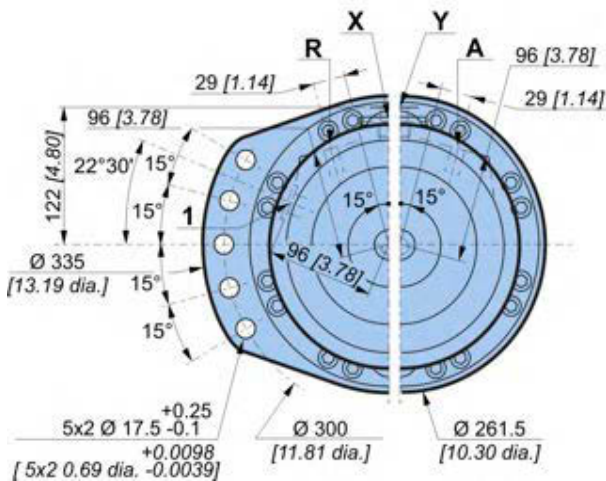
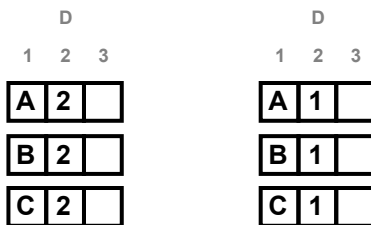



Dimensions for Twin-Lock™ valving

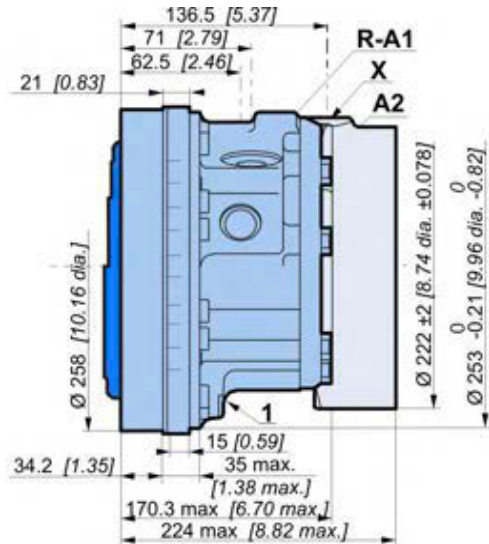
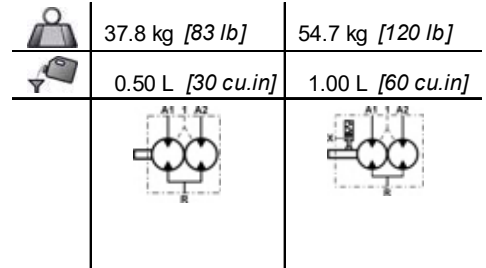
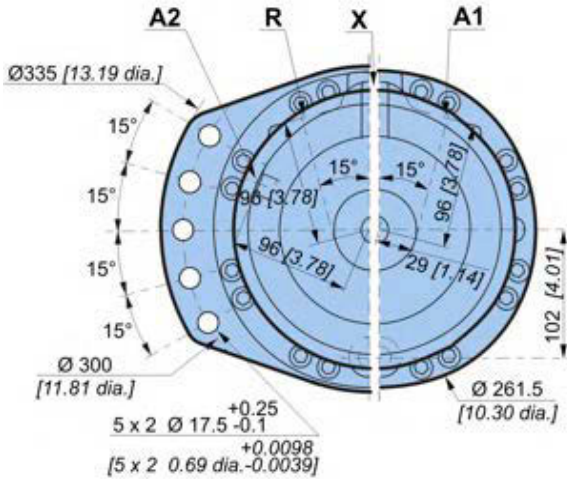
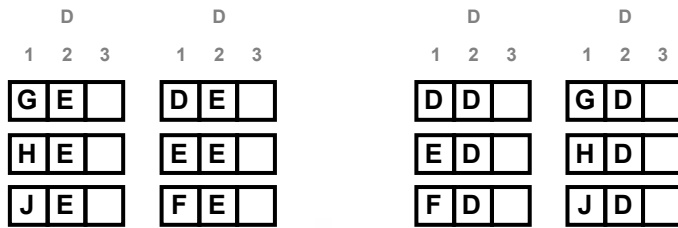

Dimensions for 1-displacement valving with built-in exchange

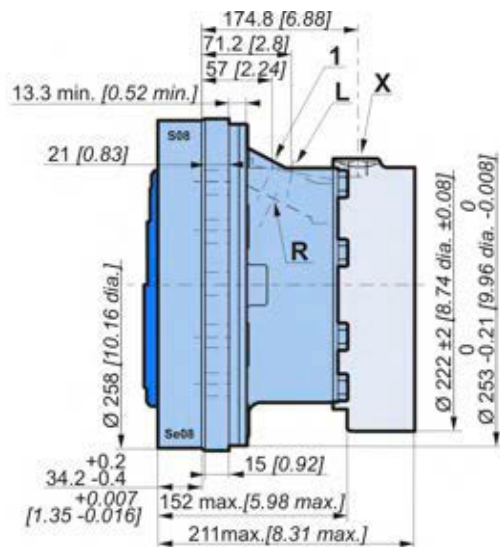
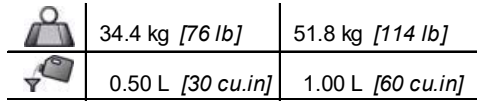
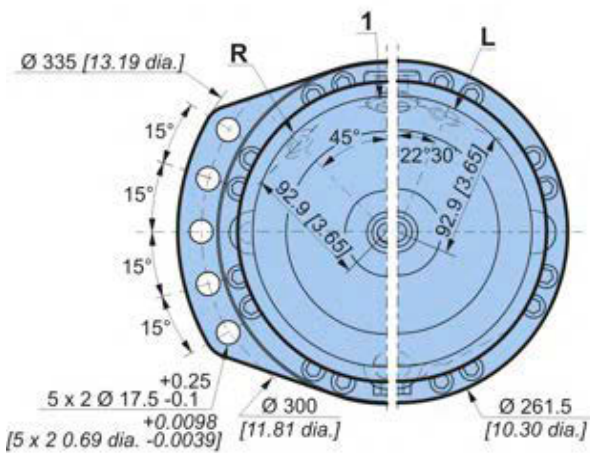

Modularity and Model code

Wheel motor

Shaft motor

Valving systems and hydrobases

Brake

Options



Exchange

When a coding request is made, you must specify information on the threshold of the selector and the valve.

Selector spool

Selector threshold bar [PSI]	Opening pressure of selector bar [PSI]
8 [116]	9.9 ±1.2 [144 ±17]

Fitted valve

P1 bar [PSI]	Q2 L/min [GPM]	P2 bar [PSI]
13.5 [195]	14 [3.7]	16 [232]
18 [261]	15 [3.9]	21 [305]
22 [319]	16 [4.2]	25 [363]

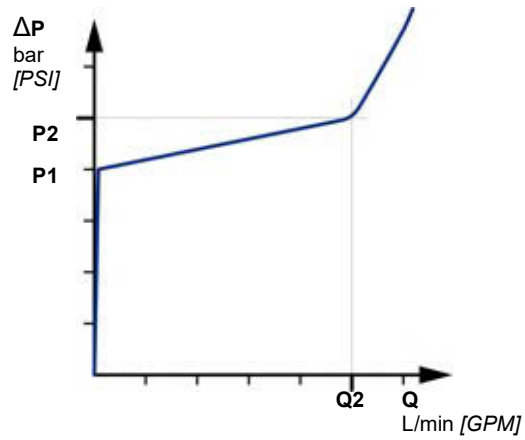

Chassis mountings

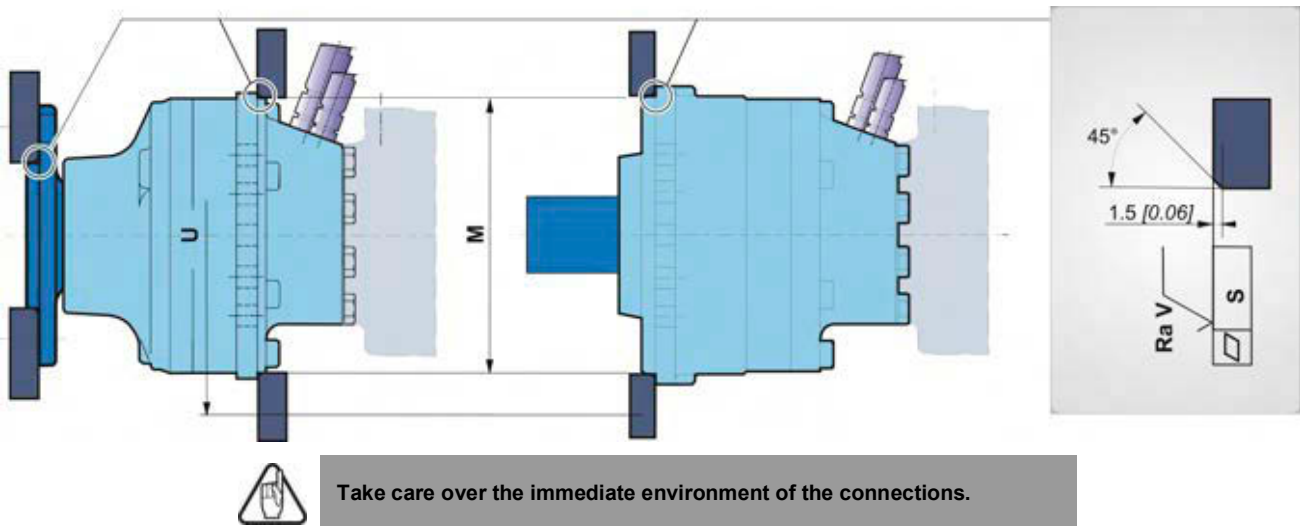

	Ø M ⁽¹⁾	Ø U	S	Ra V		Class
Wheel motor	253 [9,96]	300 [11,81]	0,2 [0,008]	12,5µm [0,49µin]	2 x 5 M16 x 2	8,8
Shaft motor	224 [8,82]	300 [11,81]				

(1) +0,3 [+0,012]
+0,2 [+0,008]





Hydraulic connections

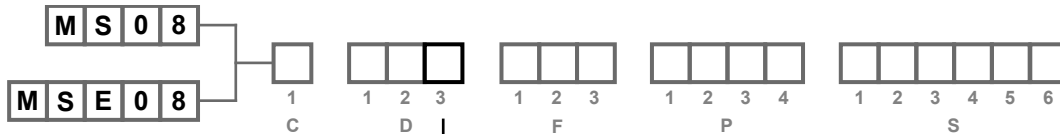
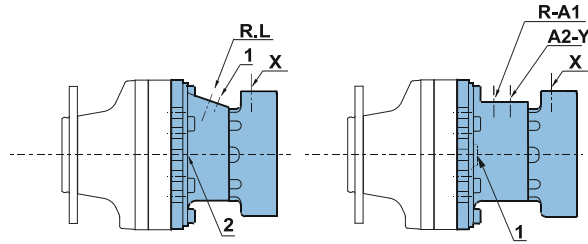

	Standards	Power supply	Standards	Case drain	2 nd displacement control	Control of parking brake
		R-L		1, 2		X
	A	ISO 11 926-1	1" 1/16-12 UNF	ISO 11 926-1	3/4"-16 UNF	9/16"-18 UNF
	1	ISO 6162	SAE 6000 PSI- 1/2"	ISO 9974-1	M18 x 1.5	M16 x 1.5
	2	ISO 6162	SAE 6000 PSI- 1/2"	ISO 1179-1	BSP 3/8	BSP 3/8
	4	ISO 9974-1	M22 x 2	ISO 9974-1	M18 x 1,5	M16 x 1.5
	5	ISO 9974-1	M27 x 2	ISO 9974-1	M18 x 1.5	M16 x 1.5
8	ISO 6149-1	M22 x 2	ISO 6149-1	M18 x 1.5	M16 x 1.5	
				1, 2	Y	X
	A	ISO 11 926-1	1"1/16-12 UNF	ISO 11 926-1	3/4"-16 UNF	9/16"-18 UNF
	1	ISO 6 162	SAE 6000 PSI- 1/2"	ISO 9974-1	M18 x 1.5	M14 x 1.5
	5	ISO 9974-1	M27 x 2	ISO 9974-1	M18 x 1.5	M14 x 1.5
				1, 2	Y	X
	A	ISO 11 926-1	1"1/16-12 UNF	ISO 11 926-1	3/4"-16 UNF	9/16"-18 UNF
	3	ISO 1179-1	BSP 3/4	ISO 1179-1	BSP 3/8	BSP 1/4
	5	ISO 9974-1	M27 x 2	ISO 9974-1	M18 x 1.5	M14 x 1.5
Max. pressures	$\frac{MS}{MSE}$ bar [PSI]	450 [6 527]		1 [15]	30 [435]	30 [435]
		400 [5 802]				



You are strongly advised to use the fluids specified in brochure "Installation guide" N° B59689D.



To find the connections' tightening torques, see the brochure "Installation guide" N° B59689D.



Do not put either a check valve or a poppet valve on the pilot lines (parking brake and displacement change) between the charge pump and the pilot valve. Do not use a piloting valve with integrated check valve.

Modularity and Model code

Wheel motor

Shaft motor

Valving systems and hydrobases

Brake

Options



Efficiency for Classic and HighFlow™ motor

Overall efficiency

Average values given for guidance for code 0 displacement after 100 hours of operation with HV46 hydraulic fluid at 50°C [122°F].

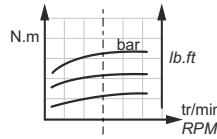
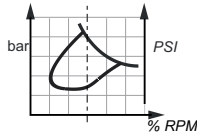

Actual output torque

MS08

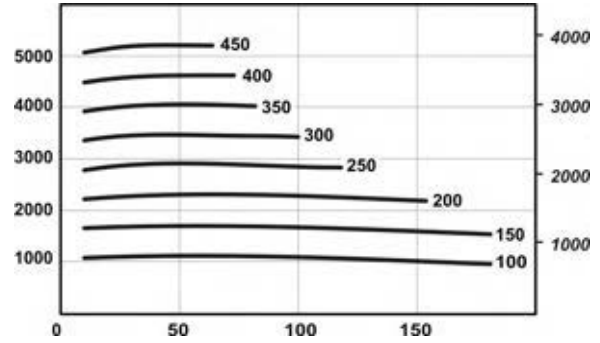
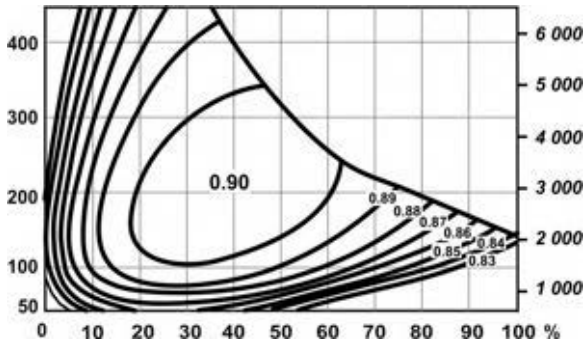

MSE08

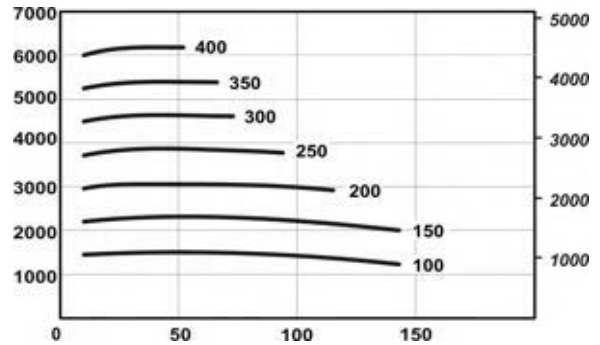
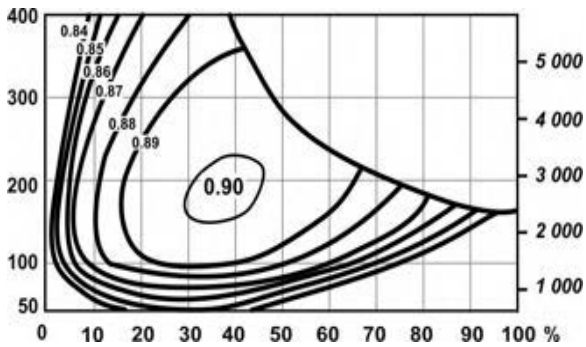

For a precise calculation, consult your Poclain Hydraulics application engineer.



BRAKES

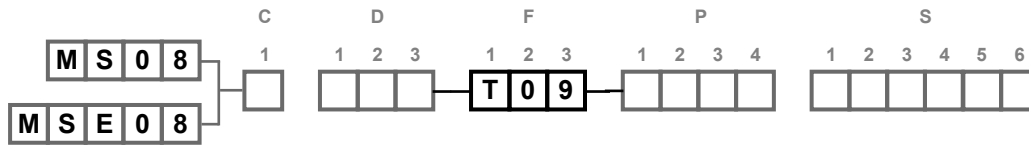

Rear brake

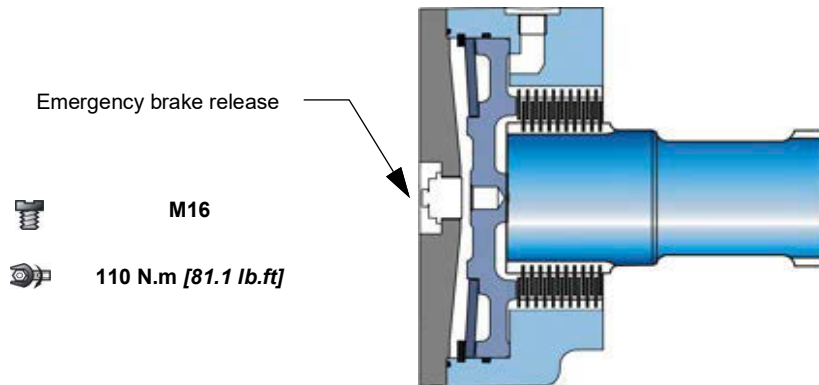

Brake principle

This is a multidisc brake which is activated by a lack of pressure. The spring exerts a force on the piston, which presses on the fixed and mobile discs, and immobilizes the shaft. The braking torque decreases in linear proportion to the brake release pressure.

C	T09
Parking brake torque at 0 bars on housing (new brake)	9,000 Nm [6,640 lb.ft]
Dynamic emergency braking torque at 0 bars on housing (max. 10 uses of emergency brakes)	5,850 Nm [4,310 lb.ft]
Residual parking braking at 0 bars on housing *	6,750 Nm [4,980 lb.ft]
Min. brake release pressure	12 bar [174 PSI]
Max. brake release pressure	30 bar [435 PSI]
Oil capacity	100 cm ³ [6.1 cu.in]
Volume for brake release	40 cm ³ [2.4 cu.in]
Max. energy dissipation	110 336 J

* After emergency brake has been used



Do not run-in the multidisc brakes.



A functional check of the parking brake must be carried out each time it is used as an auxiliary brake (or emergency brake). For all vehicles capable of speeds over 25 km/h, please contact your Poclair Hydraulics application engineer.

Modularity and Model code

Wheel motor

Shaft motor

Valving systems and hydrobases

Brake

Options



S08™ Service brake

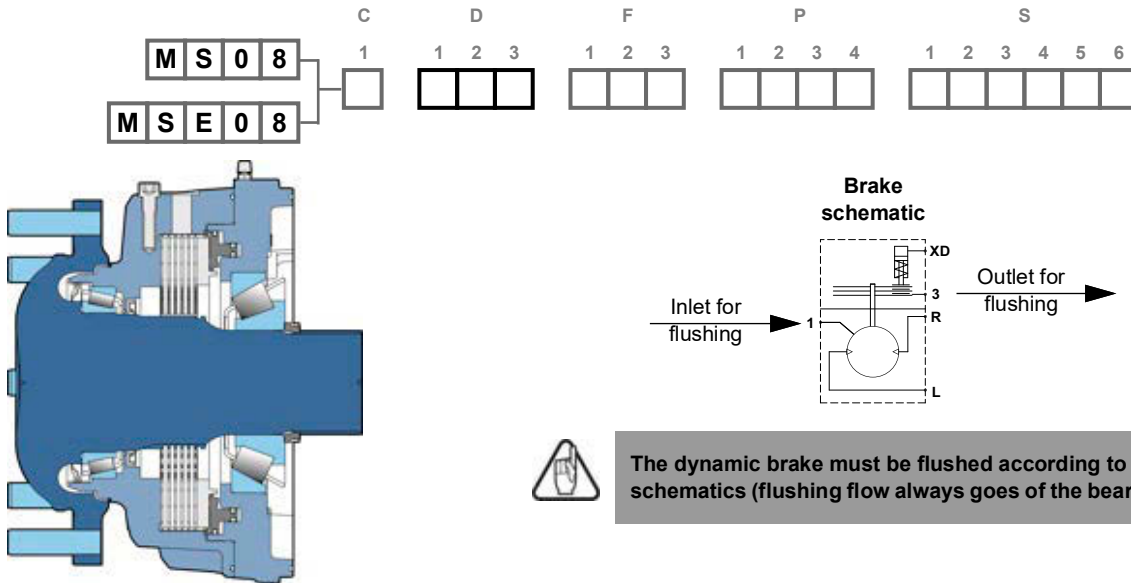





Brake principle

This is a multidisc brake which is activated by a braking pressure (dynamic braking). The braking command creates a pressure on the dynamic braking piston, which damps the fixed and free discs, preventing the shaft from turning. Braking torque increases linearly as a function of the piloting pressure.

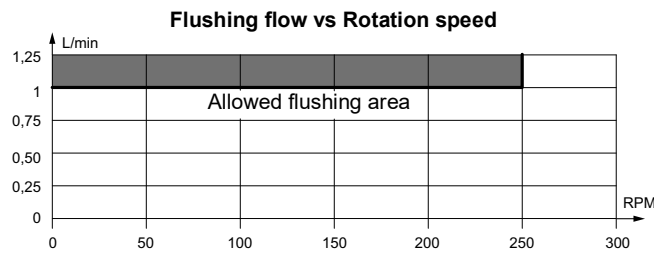
C	U	1	0	W	1	0
	V	1	0		Y	1

Max. rotation speed	250 rpm
Max. energy dissipation	350 kJ
Average torque during dynamic braking	13,000 Nm [9,590 lb.ft]
Pressure to obtain max. permissible braking	140 bar
Piston chamber piloting volume, worn brake	40,5 cm³
Service brake max. allowed energy	290 kJ



-  **Do not run-in the multidisc brakes.**
-  **The use of certain oils may not offer the characteristics stated above. Consult your Poclain Hydraulics application engineer.**
-  **A functional check of the parking brake must be carried out each time it is used as an auxiliary brake (or emergency brake). For all vehicles capable of speeds over 25 km/h, please contact your Poclain Hydraulics application engineer.**
-  **When using the Boosted brake™ option, the S08™ bearing support might not be able to withstand the combination of maximum hydrostatic torque and maximum service brake torque. Please contact your Poclain Hydraulics application engineer for a detailed calculation.**



OPTIONS

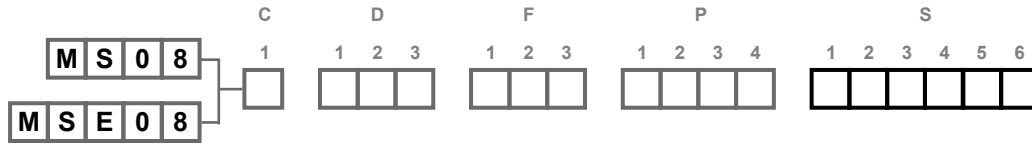

You can accumulate more than one optional part. Consult your Poclain Hydraulics sales engineer.

1 - Fluorinated elastomer seals

Nitrile seals marked in the figure below replaced by fluorinated elastomer seals.

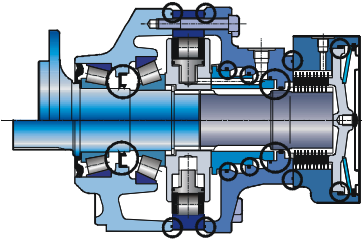

Consult your Poclain Hydraulics sales engineer.

2 - S - Q - 8 - Installed speed sensor or predisposition

Designation

T4 speed sensor (without rotation direction)	2
TR speed sensor (digital rotation direction)	S
TD speed sensor (two phase shifted frequencies)	Q
Predisposition for speed sensor	8

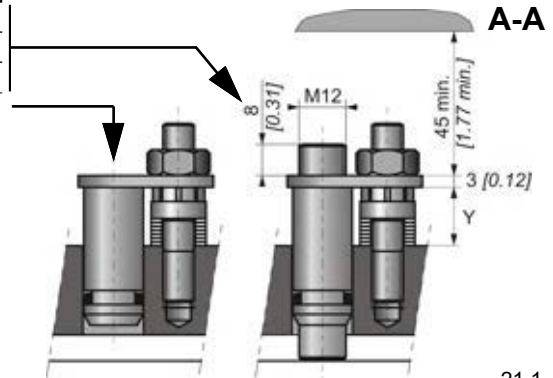
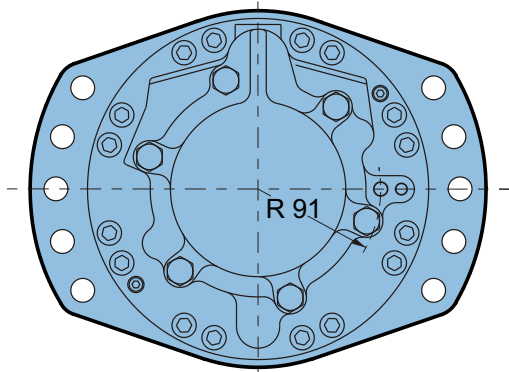

21.1
60

Max. length Y =
Standard number of pulses per revolution =



Look at the "Mobile Electronic" N° A01889D technical catalogue for the sensor specifications and its connection.



To install the sensor, see the "Installation guide" brochure No. B61352L.

Modularity and Model code

Wheel motor

Shaft motor

Valving systems and hydrobases

Brake

Options



3 - Brake environmental cover without plug

No plug or hole in the cover.

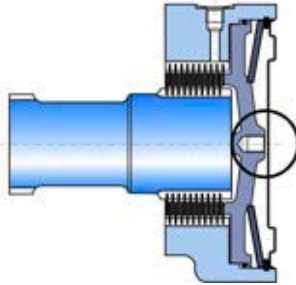

5 - Drainage

Fit an additional drain on the valving cover.

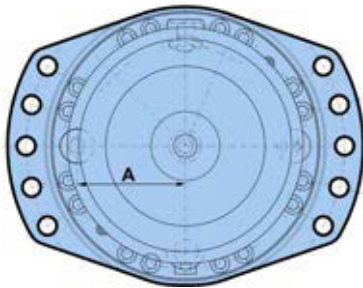

A
102 [4.02]

6 - Industrial support

Reduction of around 50% from the rated value in the bearings' preload value.



For a precise calculation, consult your Poclain Hydraulics application engineer.

7 - Diamond™

Special treatment of the motor core which considerably increases its strength, making the motor much more tolerant to temporary instances of the operating conditions being exceeded.

A - Hollow shaft

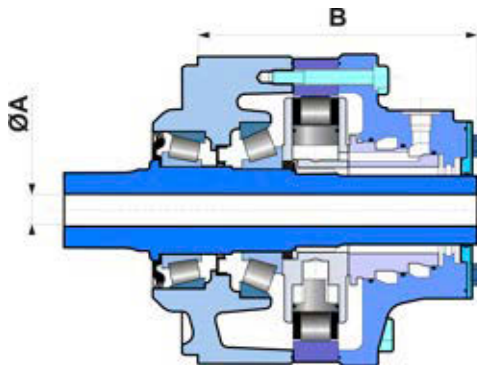

A	B
mm [in]	mm [in]
Ø 35 [1.38 dia.]	231.2 [9.10]

Radial load x 0.75
No torque allowed towards the rear



B - Drain on the bearing support

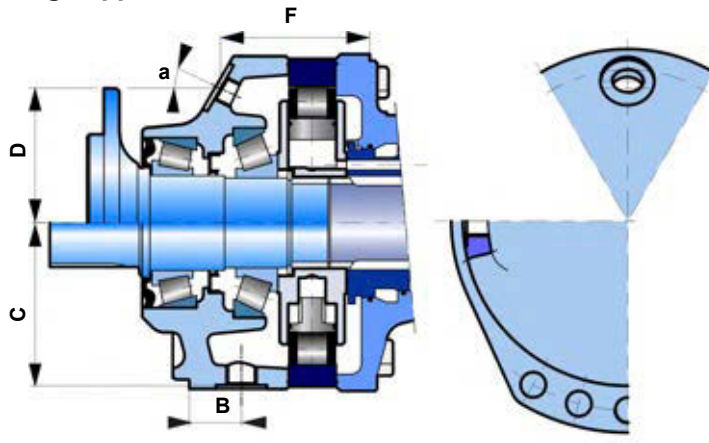

	ISO 6419-1	B mm [in]	C mm [in]	D mm [in]	F mm [in]	a
Shaft motor	M18 x 1.5	37.5 [1.5]	129 [5.08]			
Wheel motor	M18 x 1.5			105 [4.13]	89.5 [3.52]	35°
Short wheel motor	M18 x 1.5			97 [3.82]	95 [3.74]	30°

C - Abrasive environments (mechanical seal)

Certain environments can be very harmful. The mirror seal gives reinforced motor sealing.



Consult your Poclair Hydraulics sales engineer.

E - Reinforced sealing

Requires reinforcement of shaft bearings.

G - Special wheel rim mounting

Enables certain combinations different from the standard mountings defined on pages 11 and 13.



Consult your Poclair Hydraulics sales engineer.

H - High efficiency

Reinforced piston sealing to improve volumetric efficiency.



For a precise calculation, consult your Poclair Hydraulics application engineer.

Modularity and Model code

Wheel motor

Shaft motor

Valving systems and hydrobases

Brake

Options



J - Treated shaft

Heat treatment on the indicated bearing radius and splines.

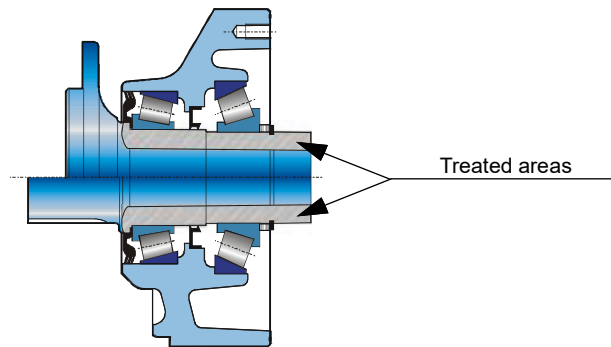

M - High speed

Under certain conditions, an increase in the maximum speed of 30% above the values indicated in the table on page 2 is possible.



For a precise calculation, consult your Poclain Hydraulics application engineer.



Option "M" becomes mandatory when selecting the HighFlow™ valving.



Modularity and Model code

Wheel motor

Shaft motor

Valving systems and hydrobases

Brake

Options





Modularity and
Model code

Wheel motor

Shaft motor

Valving systems
and hydrobases

Brake

Options



Poclain Hydraulics reserves the right to make any modifications it deems necessary to the products described in this document without prior notification. The information contained in this document must be confirmed by Poclain Hydraulics before any order is submitted.

Illustrations are not binding.

The Poclain Hydraulics brand is the property of Poclain Hydraulics S.A.

-  26/11/2024
-  801 478 119B
-  801 478 189C
-  801 578 102D
-  801 578 114R
-  801 578 126E
-  A07442P
-  Not available
-  A14241E

